

Antique Pattern Library

For more information, please see our website at: <http://www.antiquepatternlibrary.org>

This is a scan of an antique book that is, to the best of our knowledge, in the public domain. The scan itself has been edited for readability, and is licensed under the **Creative Commons** Attribution-NonCommercial-ShareAlike License. To view a copy of this license, visit <http://creativecommons.org/licenses/by-nc-sa/2.5/> or send a letter to Creative Commons, 559 Nathan Abbott Way, Stanford, California 94305, USA.

You may share copies or printouts of this scan freely. You may not sell copies or printouts.

Antique Pattern Library is a project of New Media Arts, Inc. <http://www.newmediaarts.org>, a nonprofit organization tax exempt under IRC 501(c)(3). Donations may be tax deductible, depending on your tax status and tax jurisdiction.

Donated by

Sytske Wijnsma

A COMPLETE COURSE
IN
DRESSMAKING

IN TWELVE LESSONS

BY
ISABEL DE · NYSE CONOVER

LESSON ONE
PRELIMINARY INFORMATION
INDEX

COPYRIGHT, 1921, BY EDWARD J. CLODE
ALL RIGHTS RESERVED

Edward J. Clode
Publisher, New York

A COMPLETE COURSE IN DRESSMAKING.

BY
ISABEL DENYSE CONOVER



LESSON I
PRELIMINARY INFORMATION
INDEX

NEW YORK
EDWARD J. CLODE

**COPYRIGHT, 1921, BY
EDWARD J. CLODE**

Entered at Stationers' Hall

PRINTED IN THE UNITED STATES OF AMERICA

LESSON I

WHAT DOES STYLE MEAN TO YOU?

Of course you want to be stylish. Every sensible woman does. But do you know how to acquire the well-dressing look? Is it something you are able to accomplish one time and not another? Or perhaps, you can select smart clothes for yourself and can't help Cousin Louise overcome a dowdy appearance. Or do you admire Mrs. Jones' new blue dress just because it has that quality "chic" and accept as inevitable your own unbecoming brown dress?

Has it occurred to you that you and Cousin Louise and in fact every other woman can be stylishly dressed? People may be born beautiful, but certainly they are not born stylish. It's a clothes sense that they acquire. They learn to wear clothes that are suitable. And there is the whole secret summed up in one word.

If I were asked to give a synonym for the word stylish, I think I'd say suitable. You

[1]

A COMPLETE COURSE IN DRESSMAKING

know that it doesn't make any difference how beautiful a dress may be, just as a dress, if it is inappropriate for the place or unbecoming to the wearer, you never think of it as stylish. Now do you? There are three great big important things to remember when you are selecting a dress, whether it is for yourself or for someone else.

First: It is important that the style of the dress suit the place or occasion for which it is intended.

Second: The design of the dress must suit the season—in other words be near enough to the prevailing mode not to be conspicuous.

Third: See to it that the lines and color of the dress suit the wearer.

If your dress will pass these tests, you may rest assured that it is stylish. After all, style in the true sense of the word is more than a mere Paris label, a pretty picture or a fine texture. It isn't enough for a piece of material to be charming on the counter or a style pretty in the picture. Ask yourself how the dress is going to look when you make it up and put it on or when Sally Jones wears it. Put it through the little suitability test.

Probably more errors are committed in selecting extreme styles than in any other way. To be sure, there are people who can carry off the bizarre in dress but they are the dashing

PRELIMINARY INFORMATION

type. We might as well recognize the fact in the beginning that we can't all dash.

Make the most of the looks and personality which you have. If you are demure or dignified or just pleasantly in between, watch out or the ultra styles will eclipse you.

You don't want to be remembered as a dressmaker's dummy carrying around a pretty frock or the woman who wore the tight skirt, the big collar or the queer sleeves.

I think one of the finest compliments which can be paid a person's appearance is the exclamation, "I can't remember exactly what she wore but she was dressed in such good taste and her clothes suited her splendidly".

Remember that your clothes ought to make you look your very best. Clothes can do kindly things—bring out the pretty lights in your hair, make you look an inch taller or hide the awkward curve of your hips—or they can be very, very unkind. It is not always the out-of-date dress either that is the hard task master.

A ruffle may be a charming accessory in the shop window but when roly polly Louise wears it just attract attention to the fact that her hips are unusually large. Just the fact that a dress is the latest mode—that last word in fashion—is no guarantee that it is the stylish selection for every woman.

A COMPLETE COURSE IN DRESSMAKING

It is well to keep in mind that every season brings a few extremes along with many charming wearable clothes.

There is the matter of dollars and cents, too. It is another place where it is easy to lose the true value of style. Expensive is not a synonym for stylish. It's line and cut and becomingness that counts everytime. There is no truer saying in the world that clothes are more often overdone than underdone.

Costly materials may be very beautiful in themselves but they must be cleverly handled to equal the simple charm of an inexpensive goods well cut and well made. As a matter of fact, *where the dress is becoming as a whole, in admiring it one forgets to analyse the texture.* If you will just stop and think of the pretty dresses which you have seen lately, I am sure that you will agree with me.

One must remember, too, that an



Fig. (1) Elaborate material is just as much out of place in an everyday environment as calico is in a ballroom.

PRELIMINARY INFORMATION

elaborate material is just as much out of place in an everyday environment as calico is in a ball-room. Perhaps, I ought not to have specified calico for it has come up in the world so lately that one would hardly be surprised to find it rubbing elbows with silks and satins. But this brings us back to the question of suitability again and the first rule on page 2.

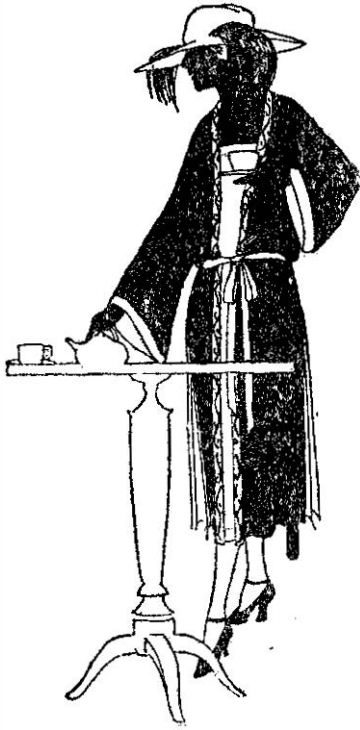

Fig. (2) Do you know what to wear for every occasion?

In order to be stylish, your clothes must suit the purpose and the occasion for which they are intended.

You may not have thought of it in just this way, but there is etiquette in clothes just the same as in table manners. Here are a few of the general rules.

CLOTHES ETIQUETTE:

CLOTHES THAT SUIT THE PLACE AND THE SEASON

Sport's Clothes. Do you know off hand just what you should wear when you golf or play tennis or ride or tramp cross country? It is pleasant to have the assurance that your clothes are just right in every particular.

A COMPLETE COURSE IN DRESSMAKING

After all, we are judged by our clothes. Whether or not they speak truthfully, to the world at large, they tell what kind of a person you are. A little attention to the small details will make them tell a pleasant story.

Suppose we consider first the *correct clothes for tennis*—that game which is becoming universally popular. Of course, no one bothers to dress specially just for a little informal game on their own side lawn. However, there is a certain type of costume that one has grown to expect in the tournaments at the country clubs.

The accepted costume is all that could be desired for comfort—a short, two-piece or plaited silk or woolen skirt and a plain tailored blouse of batiste, handkerchief linen or crepe de chine with comfortable V neck. I might add that the popular woolen sports skirt is striped.

Tennis is a hatless game. The hair ought to be dressed in a close simple manner. A narrow ribbon tied around the head, low over the forehead in the front and tied in the back is a becoming accessory which will serve to keep the hair in place.

White canvas or buckskin oxfords or shoes with flat rubber soles are the only footwear permissible for tennis.

Of course, a sweater is a necessity for after the game. Both silk and woolen sweaters

PRELIMINARY INFORMATION

are worn. One may have a subdued tone, black or any gay color that fancy dictates in the sweater.

Golf clothes seem to be in a state of evolution. At some of the smart links, women are wearing tweed suits with knickers. It must be remembered that this is the extreme, not the generally accepted custom. And it's a fact that a woman in knickerbockers is very conspicuous.

A costume that is very smart at the present time for golf consists of a tailored blouse, a sleeveless wool jersey dress and a box-coat to match. The regulation wool jersey, tweed or homespun suit which has an amply wide skirt and a belted box coat is also worn with tailored waists. Although blouses with V necks and flat collars are worn, the preferred waist is in shirt style with high soft collar. It is usually made of pongee, crepe de chine or linen and worn with a man's knitted silk tie.

In warm weather, separate woolen or silk skirts are worn with tailored waists of batiste or wash silk. To complete the costume, invariably there is a sweater.

The collapsible small felt, ribbon or straw hats are the accepted hats for golf. Shoes or oxfords of durable calfskin are to be preferred to fancy sports shoes.

There are special golf gloves with holes over the knuckles to give greater freedom to the hands.

A COMPLETE COURSE IN DRESSMAKING



Fig (3) The young girl wears a tweed riding habit with breeches.

The riding habit depends on two things: a person's age and the environment. The young girl in her 'teens wears a tweed suit consisting of a box coat and riding breeches for riding across country, in town or even for an exhibition.

This costume is usually completed with a blocked tricorne or a soft felt hat and riding boots.

Very often out in the country a woman also wears a tweed suit, box coat and breeches instead of a skirt. However, if she is riding in town, her suit is a little more formal. The coat is oxford cloth or twill and fitted. Her riding breeches are of twill or checked material or she has a divided skirt to match her coat. Her hat is either the regulation sailor or tricorne.

For indoors exhibition riding, women usually choose the side saddle which calls for the regulation side-saddle habit and high silk hat.

The ideal suit for knockabout country wear is a three-piece one of tweed, homespun or khaki. There is a coat cut in box style and belted, a pair of knickerbockers and a skirt. The skirt buttons up the front and if occasion warrants can be worn as a cape. The outfit

PRELIMINARY INFORMATION

is completed with a shirt blouse, a soft felt hat and high lace calf skin shoes.

Perhaps, when you first read the heading *Sport's Clothes*, you thought of the type of costume that has become generally popular and is called sport's clothes. I have in mind the silk skirts, dainty handmade blouses and rather elaborate sweaters which are called sport's clothes but have no place in real sports. They are the clothes which are worn in the mountains, country, seashore resorts and suburban towns for before noon and even in the afternoon for out of doors. The skirts are of fibre silk in white or a pastel shade and the blouses of batiste, lawn, voile or organdie trimmed with drawn work, handrun tucks and delicate Valenciennes filet or lace.

Clothes for Afternoon: If afternoon means calling and tea, then you need the type of a frock which is often termed "dressy." Usually an afternoon frock is of silk, but its material depends somewhat on the season.

You may indulge your inclinations in mid-summer to the extent of an organdie, batiste or mull dress for calling or afternoon. Mid-winter varies the rule also, and one might include velvet, duvetyne or broadcloth along



Fig. (4) A sensible choice for afternoon is a silk frock.

A COMPLETE COURSE IN DRESSMAKING

with silks such as chiffon, crepe de chine, Canton crepe, and charmeuse as possibilities for the afternoon type of dress.

As to style, an afternoon dress has a slightly low neck, and elbow, three-quarter, or full length sleeves. The skirt usually shows some elaboration such as a tunic or slight drapery.



Fig. (5) Choose your evening dress to suit your type.

Clothes for Evening: It is difficult to put evening clothes under just one heading for here is where a woman's age and general appearance makes a difference.

The young girl and the petite woman may choose for dances or other formal evening functions the type of costume which is generally termed a dance frock. This has a tight fitting bodice with straps on the shoulders. It may or may not have tulle sleeve caps. The skirt is short and bouffant.

The dress in vogue for the more dignified type of woman is made of rich brocade, satin

PRELIMINARY INFORMATION

or velvet and draped to the figure. Often it has a V decollete in the back and a mere wisp of the material forms a short train.

Of course, in the summertime a simple low-neck organdie dance frock is quite correct for evening.

A type of dress which is popular for restaurant dinner wear and the theatre has only a slightly low neck and no sleeves. It is made of silk, lace or velvet. It is not necessary to wear an evening dress or a restaurant dinner dress to the theatre unless one is to be seated in a box or is joining a party who are formally dressed for evening. If one's escort is wearing street clothes, it is permissible to wear street clothes such as a suit or tailored frock.

For little informal evening socials, an afternoon frock is in good taste.

If one attends evening functions, some sort of a wrap of taffeta, satin, brocade or velvet is a necessity.

With a formal evening gown one should go hatless. However, a hat is worn with a restaurant dinner dress.

Street Clothes: Whether you live in the city or the country, your wardrobe must have one or two costumes in it suitable for what is termed streetwear. It's the semi-tailored type of costume one puts on for a shopping excursion or a trip to town.

A COMPLETE COURSE IN DRESSMAKING

Of course, your street costume may be a suit, completed with a georgette or dainty hand-made batiste blouse. However, many women prefer a one-piece dress.

For cool weather a serge, tricotine, velour or wool jersey is a good choice for a dress. With this a wrap is necessary for mid-winter. In early fall or late spring, the dress is often worn with a fur neck piece. Linen and gingham and dark colored organdies make attractive summer street dresses. Navy, brown and black silk are also made in plain styles for the street.

The hat worn with the street dress or suit ought to be neither severely tailored nor elaborate. It's the medium size or small hat with a touch of trimming—one might almost say in-between hat—that looks the best with this type of costume.

While women do not follow the rules concerning footwear as closely as they used to, strictly speaking, the correct shoe or oxford for the street has a straight heel.

When You Travel: Either a suit or a dark one-piece dress is correct to wear on the train. A small semi-tailored hat is to be preferred to a large one. A pullman robe of dark cotton, silk or corduroy, which is worn from the berth to the dressing room, is in better taste than a light or bright colored kimono.

PRELIMINARY INFORMATION

It is a matter of taste, whether or not a woman wears her hat in the dining car.

In some hotels it is really necessary to dress for dinner. The style of dinner dresses varies, but usually the neck is low and the sleeves very short or the dress is sleeveless.

Fig. (6) A top coat is a necessity for an ocean voyage.

Satin, brocades, velvet and crepe silks and lace are used for dinner dresses.

However, in the majority of hotels it is permissible to wear a street costume or an afternoon frock for dinner. On the other hand, on shipboard one is expected to dress for dinner. As a matter of fact, it is well to take two evening dresses, one on the order of a dinner dress with only a slightly low neck, and the other a more elaborate evening gown as there is usually some special occasion for which one needs it.

Besides a suit, one needs a warm top coat if taking an ocean voyage. While it is not a necessity, a sports costume consisting of a silk



A COMPLETE COURSE IN DRESSMAKING

or wool skirt and sweater or jersey jacket adds a nice change.

The Business Woman: Just because a woman is a business woman is no reason why she must lose her feminine attractiveness or dress so very differently from other women. On the other hand, she doesn't want to look out of place. The one-piece dress has been a boon to her. It is her special standby.

For cool weather, a dress of serge, twill or velour freshened up with several changes of dainty collars and cuffs of batiste or organdie will keep her looking spic and span and attractive, too, six days in the week.

Navy blue or brown linen, gingham, swiss or organdie make an inconspicuous and serviceable office dress for summer. It's a good idea, too, having a dark silk office dress made in some plain becoming style.

There are certain types of sports costumes which are suited to the business woman's purpose. Wool jersey and homespun suits are among these. A silk skirt, a dainty blouse, and a sweater is also quite in keeping with an office.



Fig. (7) The one-piece dress is a boon to the business woman.

PRELIMINARY INFORMATION

CORRECT MOURNING

Ideas about mourning have changed in the past few years. Now a person wears mourning or not according to their own inclination. The tendency of the times is to wear lighter mourning, and lessen the periods of mourning. However, a few general suggestions may prove helpful.

The Periods of Mourning: A widow wears mourning from one to two years. You will remember that it was only a little while ago when a widow hesitated to take off mourning in the third year, and our grandmothers can remember when it was a life-time proposition. Another thing which has changed about mourning is what was called third mourning. This has been entirely dispensed with.

The period of mourning is divided in two. That is, if a person is going to wear mourning for a year, the first six months deep mourning is worn and the second six months, second mourning. First mourning is mostly black; second mourning black and white. The old-time third mourning, lavender and gray, isn't necessary now. When a person leaves off black and white, which is second mourning, they may wear any inconspicuous shade they fancy.

Mourning for parents or a child is usually worn one year. And the same is true for a brother or sister. Nowadays, mourning is not

A COMPLETE COURSE IN DRESSMAKING

worn for any one outside of the immediate family. Of course, one is expected to wear black, or a very dull, inconspicuous costume to a funeral.

First Mourning: Not all black materials are considered appropriate for deep mourning. The choice should be a dull woolen or silk. Woolens considered correct are serge, poplin, gabardine, tricotine, jersey and velour. Silks that may be worn for deep mourning are crepe de chine, Canton crepe, faille, pongee, chiffon and georgette. In cottons, one may choose oxford gingham, black linen, mull, organdie or swiss. Fancy trimmings are to be avoided.

As a person in deep mourning does not attend formal social gatherings, only simple clothes suitable for home and street wear are needed. One may have a woolen suit and several crepe de chine, taffeta and georgette blouses or a dress fairly plain, but made in an approved and becoming style, and a top coat to wear with it.

Even in deep mourning, narrow turn-back collars and cuffs of white are worn. These may be white crepe, but nowadays crepe is not worn as much as heretofore. Batiste, voile or organdie for the collar and cuffs are in equally good taste. These are usually held in place with dull black bar pins. Gold and platinum jewelry is not worn except the

PRELIMINARY INFORMATION

wedding and engagement ring. A jet chain is sometimes worn.

The correct mourning hat is small or medium in size. One ought to remember that there is no reason for it being unbecoming. Fancy trimmings are out of place on such a hat. Feathers are never used for mourning. Just a fold of the hat material or crepe is the most appropriate trimming for a first mourning hat. Even in this case, the hat may have the underbrim faced with white. Either white crepe or white georgette is used for this purpose.

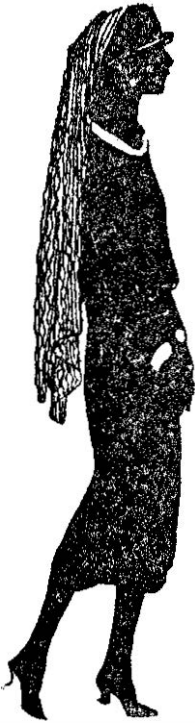

*Fig. (8) Only
a widow
wears a long
veil.*

If a widow chooses, she may wear a long veil. However, many women now feel they would rather dispense with it. When I say long veil, I do not mean extremely long. None of the veils are longer than two yards now. Such a veil is draped across the top of the crown of the hat. It is not worn over the face, except at the funeral. The veils are made of grenadine, crepe, georgette crepe, or net bordered with crepe. The borders are about three inches wide. It is a matter of taste whether or not a face veil is worn with the long veil. No one but a widow wears a long veil. The face veil for deep mourning is plain mesh and bor-

A COMPLETE COURSE IN DRESSMAKING

dered with crepe, one and one-half inches wide. One may have the border of the face veil grosgrain ribbon if preferred. In fact, the crepe is not used on the veil unless the hat is trimmed with crepe.

Mourning handkerchiefs no longer have a deep border of black. Just a very narrow black rolled edge is the approved style.

If one is mourning a parent, a child or a sister or brother, more white is worn with the black. For instance, instead of just the white collar and cuffs, a dress may have a white vest.

All white is considered just as deep mourning as black.

Second Mourning: No crepe is worn in second mourning, and more white is introduced. It is permissible to wear a white blouse with a black skirt or a black and white dress, as a figured foulard or a black dotted white swiss. White net often is used as trimming in second mourning.

After second mourning, it is wise to choose subdued colors, such as taupe, dark blue and brown before wearing bright colors.

HOW TO USE YOUR FASHION MAGAZINES

Do you get full value out of your fashion magazines? Do they bring the style centers into your sewing room? Do they talk to you and tell you that sleeves are long, or three-

PRELIMINARY INFORMATION

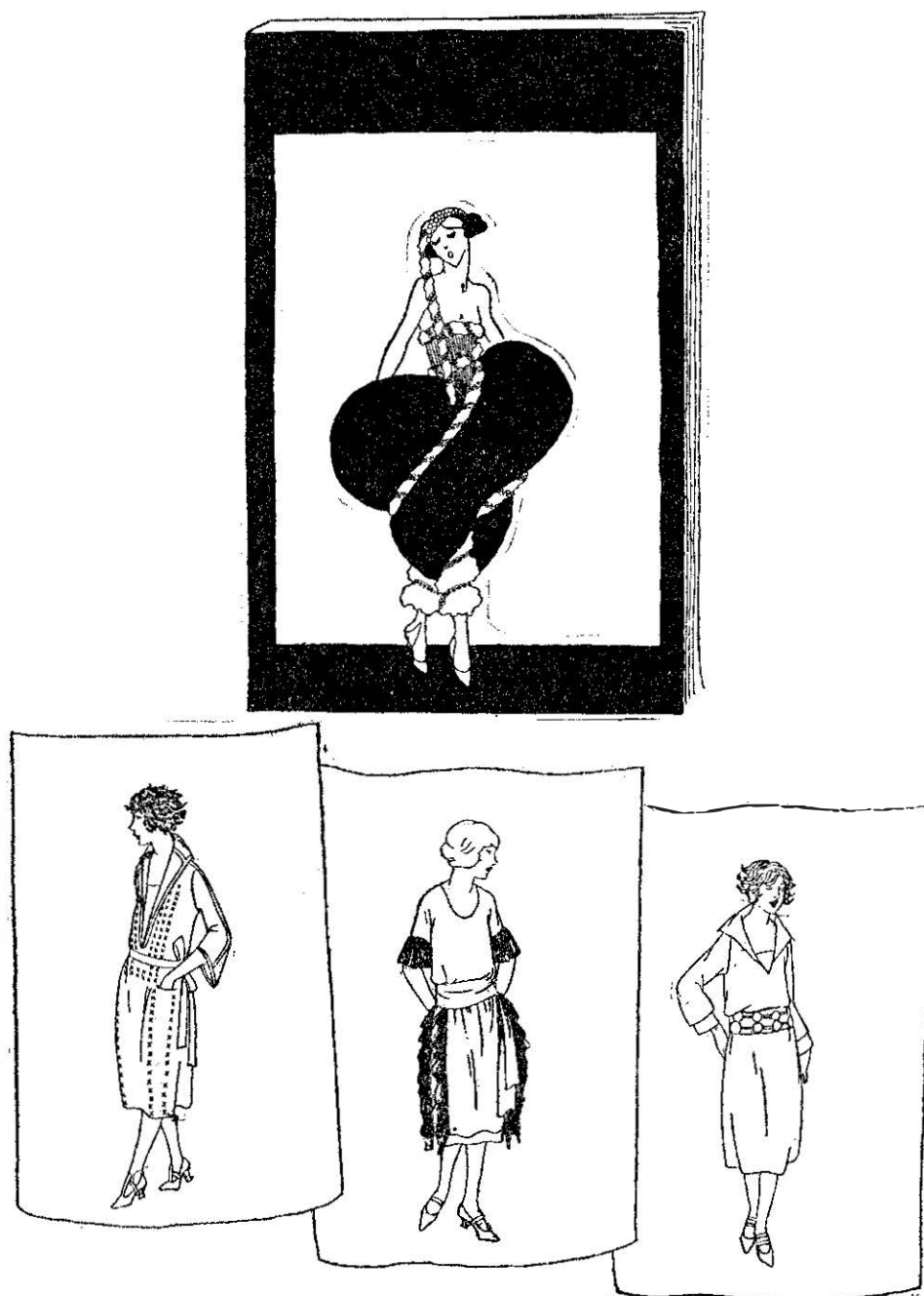

Fig. (9) Compare the designs that suit your purpose and your type. It will facilitate your selection.

quarter, or short, this season; that necks are oval, or boat shape, or perhaps square; that skirts are so long and so wide? Do they give

A COMPLETE COURSE IN DRESSMAKING

you a list of the dresses that you can wear, and those that are suited to Mrs. Somebody Else?

Now don't blame your fashion magazines if they are not doing all these things for you. The information is there. It's just a case that you haven't digested it.

Study your magazines.

It's really a pleasant pastime for an odd fifteen minutes or so. First, take the question of sleeves. It isn't necessary to read endless printed pages to find out what they are like, and what they are not like. Run through the pages and *look at just sleeves*. Make a mental note of what they are like. You can't take in everything about all the styles at one time, you know.

After you have mastered sleeves, *study the neck line*. Perhaps, you will find there are two outlines that are equally stylish.

Then there is the question of the placing of the waistline. It needs watching. What it does one season it hardly ever repeats the next. Look through all your fashion magazines and *make a study of just waistlines*.

The width and length of the skirt is another question that ought to be looked up. It's helpful also to *classify trimmings* just by themselves.

Once you have dissected the dresses, coats and suits, part for part, you will have a good

PRELIMINARY INFORMATION

mental picture of the general lines of the style for the season.

Knowing the styles is really a most important step toward having "style sense." Go back to our second rule in selecting a really stylish garment on Page 2. *The dress must suit the season.*

Now try something which may prove a little more difficult. *Classify the styles.* Turn to the first page of the magazine and decide for what purpose and occasion each costume is intended. You may be surprised to find out that you haven't been observing in times past. If you are in doubt regarding any of the pictures, refer to the rules of Clothes Etiquette.

If you want to select a style for yourself, it's a good plan to mark the designs that suit your purpose and that also will be becoming to your type. When you compare them, eliminating those that are not suitable for your purpose or your appearance, it will be an easy matter to make a choice.

Here is where, making your dress yourself is going to help out. You can adapt the style to your purpose or to suit your individuality. In fact, the placing of a waistline one inch lower, the shortening of a collar, or the lengthening of a tunic may be the difference between a becoming and an unbecoming frock. If you make your own clothes, you will have stylish

A COMPLETE COURSE IN DRESSMAKING

clothes, prettier clothes—*clothes that suit your individuality.*

WHAT IS YOUR TYPE?

Perhaps it's an impertinent question but we are talking just friend to friend and I am going to ask, "How old are you?"

Or maybe I had better say, "How young are you?"

In selecting clothes, you know, age is just as important to the slip of a girl as it is to the woman who is growing older. Sixty's dress can be downright cruel to sweet sixteen.

On the other hand, the too-young dress is the very thing that will add ten years to a woman's looks.

Decide your type and see which styles are best suited to you.

Are you a slim young girl?

Are you a stout young girl?

Are you a young woman of medium build?

Are you a stout younger woman?

Are you short?

Are you tall?

Are you thin?

Are you an older woman?

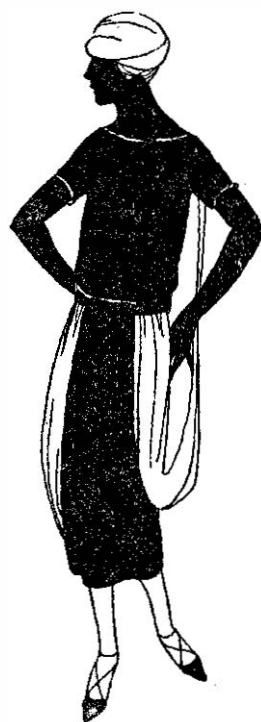

Fig. (10) Grecian draperies belong to the girl with the Grecian profile.

PRELIMINARY INFORMATION

If You Are a Slim Young Girl.—Then simplicity is your biggest asset. If you are sixteen or in your early twenties, you are sure to look your prettiest in simply tailored suits and crisp dimity or batiste Buster Brown blouses.



Fig. (11) If you are a slim young girl, you can wear a basque dress with a bouffant skirt.

Suitability in your tricotine or serge dress is just the matter of a youthful style and enough but not too much trimming.

A braid binding or a contrasting piping is far more effective than a showy beaded or embroidered trimming.

This doesn't mean that you can't indulge your fancy for frivolous things. *It's every girl's privilege to have endless pretty organdie, net and lace collar and cuffs sets.* Now that you are going to sew, you know, you can make them for a very small cost.

When it comes to your silk frock I am tempted to say taffeta—it is so becoming to the young girl. However, if satin or a crepe weave appeals to you more, have them by all means but be doubly careful that the style you

A COMPLETE COURSE IN DRESSMAKING

select is youthful. Crepes and satins are both tricky. *You don't want your dress to look as if you borrowed it from mother or Aunt Mabel.*

Of course, for evening, there is nothing like taffeta, taffeta and lace or taffeta and tulle. Here you may have the frock bouffant to your heart's content and trimmed too.

I wonder if you will mind my adding just a few don'ts.

Don't wear a quantity of imitation jewelry and spoil your pretty costume. Try just your wrist watch with your serge or tricotine and see if it doesn't look better. Remember too, that there's nothing like a simple string of pearls to set off an evening frock.

Don't overdo the styles. After all, clothes are just a frame for one's personality. You want people to remember you; not that your skirt was short or long or tight or full.

Don't copy some one else's clothes, unless they happen to be your age and your type. Miss a-hundred-and-sixty and Miss not-quite-a-hundred-and-five were never intended to be twins.

Perhaps You Are One of the Stout Young Girls.—Of course you can't have some of the things that slim young girls have—ruffles, puffings and frills for instance. However there's danger in swinging too far the other way.

PRELIMINARY INFORMATION

Just because you are plump is no reason why you must wear "stout styles for older women." You can have youthful simplicity in straight lines and long lines.



Fig (12) The straight silhouette is the becoming silhouette for the stout young girl.

Dresses of one material and all one color are to be preferred to separate waists and skirts which cut you in two. Russian blouse styles and straight hanging dresses are usually becoming. Pay particular attention to the belt. A narrow belt, placed at a slightly low waistline is better than a broad one placed high.

If you wear a suit you will find a blouse that matches the skirt in color is more becoming than a decided contrast. There are many pretty blouses now that lap over the skirt, and give long lines. Those of wool jersey and crepe de chine, finished with a V neck and detachable linen collar and cuffs are especially youthful.

Perhaps you haven't thought of it, but you can wear almost any pleated skirt except an accordion plaited one. The accordion plaits are bunched, but the side or box-pleats really give graceful long lines. In a soft material or a summer dress, you might even chance a frill, if it isn't too wide and runs up and down

A COMPLETE COURSE IN DRESSMAKING

the side seams of the skirt. You see, placed lengthwise it, too, gives a long line.

It almost goes without saying that cross-wise trimmings are taboo. Trimming can be put on to give length.

Plain materials are less likely to make you look large than figured ones. Narrow stripes are permissible but never broad stripes or plaids.

Soft materials are best but avoid a material that “cups” to the figure like wool jersey or tricolette.

Probably, this sounds like a great many don'ts to you, but there are any number of pretty materials that you can safely choose. French serge, tricotine, tweed, crepe de chine, georgette, soft taffeta, cotton crepe, voile and batiste are examples.

There are stout girls who wear capes well, but they are the tall stout girls. If you are just medium or short and plump, a coat that is belted trimly with a narrow belt will give you better lines. *In any event, avoid a cape. It is almost the worst enemy the stout young girl has.*

The pockets on your coat ought to be inconspicuous—never the large plastery patch pocket variety. You may have this to console you, that, anyway, slashed pockets, placed lengthwise, are smarter now.

PRELIMINARY INFORMATION

The collar, too, ought never to be more than medium in size. Collars that border on the cape variety seem to add many inches in width.

It is possible to add trimming to a coat that will give long lines. Rows of parallel machine stitching, lengthwise at the center back or sides will give a pleasing effect.

When you choose a suit, pay particular attention to the length of the jacket. The bolero and waistline jacket are not for you. Hunt out the coat that is finger tip length or longer. A simple box coat with perhaps an inverted pleat at the center back to give added length, and the narrowest kind of a belt, you will find answers the requirements for a youthful look and a becoming line.

All you have to do is to compare in your mind's eye this type of coat with one that is fitted in body and flaring below the waistline to be convinced of the wisdom of straight lines.

I want to add just a few more suggestions. The first is about the fit of your clothes.

Don't skimp your clothes. A tight dress never make a person look smaller. In fact, tightness is apt to accentuate the size of the bust, the bigness of the arms and the width of the thighs. Try a little fullness, it will do wonders in the way of hiding large hips.

There is the question, too, of the length of your skirts. If you wear your skirts a little

A COMPLETE COURSE IN DRESSMAKING

bit longer than the slim girl, you will find they will give you added height.

Even your hat can add to your height or take away from it. Perhaps, the best rule I can give you to follow is to avoid broad brims and shallow crowns. There is danger, too, in the mushroom brim, although a brim that is medium in size and only droops slightly is often very becoming. A turban or a round hat with a decidedly upward brim is also to be avoided. Even when you have eliminated all these, you will find that you have a wide selection among the hats that have medium brims and fairly high crowns. Try on your hat in front of a full length mirror.



Fig. (13) The woman of medium build can wear almost any fashion.

Or Are You a Young Woman of Medium Build?—I am thinking of the girls, say twenty-eight years old or in their early thirties, whose figures are beginning to round out a little more. If you are in that class, watch out and avoid that pinched in “waisty” look.

What you want are young clothes, but they can be a trifle more sophisticated than the girl in her 'teens wears. You can break away from

PRELIMINARY INFORMATION

utter simplicity and have loose panels and tunics and coat effects.

But you want to be very careful about what you put under that pretty new frock. How about your corset? Is it making you look your very best? You know you can't go on wearing the same little girdle that you did when you were just a girl.

Watch out for your hips. The too-light corset is a hip builder, you know. Perhaps you relax more now and don't exercise so much—that is, hip reducing exercise that you indulged in ten years ago. Take a good look at yourself in the glass. If your hips spread, it is time to change corsets.

There are special corsets designed just for your type—for the young woman of medium build. They give a nice straight line in the back and hold in the hips.

What you wear over your corset counts too. The new straight loose dresses look much better when worn over a straight slip than over a waistline petticoat which is apt to make a break at the waistline.

When it comes to your outer apparel, you can have clothes with more trimming than your younger sister's. Instead of the girlish styles, look for those that have a little more dignity along with their style. It can be just as dashing a style, just as becoming a style, but you might as well admit the fact that it must be a trifle older.

A COMPLETE COURSE IN DRESSMAKING

You will find probably that a hat with a little trimming well placed is more becoming than a severely plain one. You will be wise to stick to small or medium size hats. As a matter of fact, *a hat is never becoming that extends beyond the width of the shoulders.* It's a good rule to remember.

A blouse that has a square or round or V neck is apt to suit you better than one with a Buster Brown or flat Peter Pan collar.

In dresses, keep to fairly straight lines. Leave the fitted basque and petite flaring skirt for your little sister—that is if you are thinking about a street dress.

There is an exception to the straight silhouette in your case and that is the dance frock. Here you have the choice of two types—the bodice topped dress with bouffant skirt or the straight frock that's often made of spangles or beads.

There is the matter of coats and suits, too! You can choose a dressier suit than the young girl without fear of over-doing it. Your suit may be soft velour, hand embroidered, and if it's winter, banded with fur. The same rule holds true in your top coat. Unless it is for sports or the country, the fabric may be luxuriant, and trimmed.

As to material, you are at the happy in-between age when you can have just about anything your heart desires.

PRELIMINARY INFORMATION

Your summer cottons may be gay calico, subdued gingham, plain linen, or a frilly organdie. In silks, your choice may be transparent georgette or a heavy Canton crepe. You don't have to consider if wool jersey is too clinging, for you are still slim enough to wear it. It is true, too, that you may choose plaid or check if it happens to appeal to you.

There are rules for trimming that even the perfectly developed woman is wise to follow. *A great many lines that run around the figure are seldom pleasing.* If you have seen a skirt that was braided at regular intervals from the lower edge to the waistline, you will know what I mean. It is tiresome.

Never combine two colors in a dress in exactly equal proportions. The dress will be much prettier if one shade predominates or at least forms two-thirds of the dress.

A word about jewelry goes right along with trimmings. *If your dress is elaborately trimmed, don't add ornaments in the way of jewelry.* One will spoil the other. If you are planning to wear a pendant or colorful placque on a silk cord, choose a plain style for your dress. A bright red or jade placque hanging on the front of a dark blue or black dress is really all the trimming it needs. Sometimes, too, just a bright bar pin will add the right spot of color.

A COMPLETE COURSE IN DRESSMAKING

Would You Be Classed as a Stout Younger Woman?—Perhaps you, too, are in your twenties or early thirties but are frankly stout and have oh, so much difficulty finding suitable clothes—clothes that don't make you look like a dowager. You will have to take

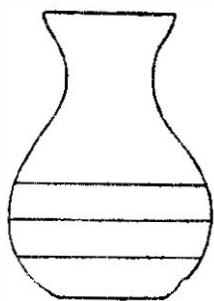

Fig. (14) Cross-wise lines make even a vase look shorter and wider.

some of the advice that I gave the stout young girl.

Watch out for the fit. Don't fit your clothes too much. An easy fit, soft folds and a little fullness will do more than anything else in the world to give you the youthful look.

The waistline is especially important. Ease it up a little. Let out your inside grosgrain dress belt an inch or so and get a straight silhouette.

Then, it is possible you know, to make yourself look taller and slighter than you really are. It's just the same sort of a trick that is shown in Figs. (14) and (15). Of course, the vase with the up and down lines looks the taller. That's what you want to do with your clothes. *Keep the lines running up and down.* I am thinking of tunics and panels and coat dresses that give height to the figure.

However, up and down lines won't do everything. There's broad stripes, for instance, the contrast in color makes you conspicuous and adds to your size. A decided contrast

PRELIMINARY INFORMATION

in the color of two fabrics in one dress will do practically the same thing.

The little Fig. (14) speaks for itself—*avoid crosswise lines if you value a graceful appearance.* Separate waists and skirts of different colors will never make you look slimmer. A three-piece suit which consists of a one-piece dress and coat is the admirable solution of the suit problem.

If you wear a blouse at all, have it in a color that matches the skirt and in a style that laps over the skirt to avoid the break at the waistline. Of course, you have to have a belt, but make it a narrow one and always of material the same color of the dress. In fact, the belt is more becoming if you have it of goods the same as the dress.

Your arms are apt to look larger in transparent sleeves. If your dress is chiffon, try making your sleeves double of the goods. You will find that set-in sleeves are not only more comfortable but will look better than kimono sleeves. Long, close-fitting sleeves are more becoming than short or flaring sleeves.

The V-neck outline gives the longest lines but there are some oval necks that do not broaden the figure greatly. Square necks are not so good, neither are round necks nor the straight across, boat-shaped outline.

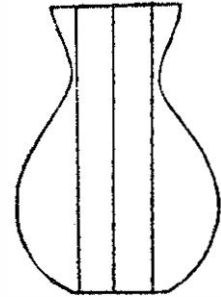

Fig. (15) Perpendicular lines give height to an object.

A COMPLETE COURSE IN DRESSMAKING



Fig. (16) Coat dresses are becoming to the stout woman.

Probably, you have learned by experience that the skirt of medium proportions looks far better than a narrow or extremely flaring one, regardless of the ultra style of the particular season.

There is your hat, too! It's another part of your costume that comes under the rule of medium. A large hat will make you look shorter and an extremely small hat will emphasize the width of your figure.

I am going to tell you the materials not to wear—stiff goods, wiry goods, goods that cling, bulky goods or conspicuously patterned or brightly colored fabrics.

After all, they are not much of a temptation when you think how attractive the crepe silks are and that most desirable woolens such as velour, serge, broadcloth and tricotine are soft, to say nothing of cottons such as crepe, voile and gingham tissue.

Even in cottons, it is safest to choose a plain color in preference to a patterned goods. Sometime try a plain blue or brown voile and see what slim lines it gives you.

PRELIMINARY INFORMATION

If You Are Short.—Which class of short women do you belong to, short and slim or short and stout or just medium?

If you are short and slim, dressing becomingly ought not to be a very difficult proposition.

There are just two or three things I would like to put the danger mark on. One of them is dressing your hair high. If you build it up into an exaggerated coiffure, you will look top heavy and call attention to your lack of height.

You have much the same problem with your hat—wings that shoot up in the air, bows that are placed high, egrets standing upright are almost never becoming to the small woman.

I advise studying the height of the heels of your shoes, too. A very high heel—higher than other women are wearing—will make people think that you are trying to make yourself look taller than you are.

Make the most of your appearance—your height—as it is. *You know you can make yourself look taller without anyone suspecting it by choosing clothes that have long lines.* However, if you are short and slim, your charm is in the very fact that you are small and petite and you can wear almost any style that fashion dictates, avoiding an elaboration of drapery on a skirt, or a voluminous wrap or extremely large figured materials.

A COMPLETE COURSE IN DRESSMAKING



Fig. (17) If you are short, choose either a short or a three-quarter coat—never one that cuts you just in two.

Some of the styles which you can wear well are what are called sport's clothes: the pretty sweaters, plaited skirts, and dainty hand-made blouses. Dresses that have a low bloused-over waist are also becoming to the slim, short woman.

If you belong to that petite girlish type, try the basque type of dress with a full skirt, or a fitted coat with a ripple peplum.

You may have ruffles and frills to your heart's content, but avoid an elaboration of drapery that may seem to weight you down. Now, haven't you seen a dainty little woman whom you felt downright sorry for because her clothes seemed such a load to carry around.

And now you women who are short and stout!—Your problem is almost identical to the taller stout woman's problem. Pick out the styles that have long lines. If you wear a tunic it ought to be a long one.

Keep your waistline as low as possible, it will give you a more graceful appearance than a bunched short waist.

PRELIMINARY INFORMATION

Don't wear a suit coat that cuts you right in two. A hip-length coat or a three-quarter coat is far more becoming.

A belted top coat is to be preferred to a bulky wrap or cape.

If you wear a fur, choose a small neck-piece and have a short-haired pelt such as mole, beaver or seal.

Study yourself as a whole and balance your costume. Don't trust a shoulder length or a waistline mirror. A hat may be becoming to your face, but be top heavy for your body. *It takes a full-length mirror to make us see ourselves as others see us.*

There is the question of the length of skirt! You can't make a rule of so many inches from the floor that will apply to everyone. It may be just above the shoe tops for the tall woman, but half-way to the knees of a short woman.

Standing on a chair and looking in a small mirror doesn't tell much either. A cut-off view of feet, ankles and skirt may look very graceful, and yet the length of skirt from bottom to waistline may be very awkward.

There is danger in the too-short skirt for the short woman. One short woman expressed the idea concisely herself, when she said, "She didn't want her skirt to look like a ruffle." It's a fact, that often an inch on

A COMPLETE COURSE IN DRESSMAKING

the length of your skirt will seem to add an inch to your height.

There is one point which you must bear in mind when looking at special designs for stout women—that *the massive type of big stout women require different styles than you do.* They can wear designs that are cut up in a great many pieces—that is, have a great many up and down lines in them. On the other hand, you will look much better in a simpler type of dress, one perhaps that has just a panel or a single line of trimming down each side of the front. For you, the dress of many pieces is in the same class as a figured dress.

It's a mistake to think that your clothes must be tight. It's not the stylish conception any more. In soft materials, a little fullness in a skirt is becoming. A short stout woman can wear a straight hanging dress, too, if the belt is narrow and slants down in the front.

As a rule, V necks are the most becoming. The longer the V, the better. You know a deep V gives a chance for the becoming touch of white.

Just mark kimono sleeves taboo, for they are apt to make a person look hunched in the back and very, very wide. *Full length, set-in, close-fitting sleeves will make your arms look slimmer.*

PRELIMINARY INFORMATION

If you are short and stout, look up the color suggestions on page 64.

Or maybe you are short and just medium.— I am going to ask you to read what I told the short, slim woman about her coiffure, her hat and the heels of her shoes.

You ought to watch out for long lines in clothes and avoid cut-off cross lines.

Draperies are not for you either.

And use frills sparingly on your blouse.

There is the question of trimming, too. An elaborate beaded or embroidered all-over design is just as bad as a figured goods.

Make simplicity the keynote of your wardrobe. Fancy clothes will take away from your height and your individuality, too. Plain good style clothes have a dignity and smartness which is your special privilege.

Starting in with dresses, straight hanging dresses will give you good lines, especially if the trimming runs up and down. You can wear over-blouse styles, too, and coat dresses.

Suit coats ought to be finger-tip length or longer. You can't afford to chance a line that cuts you right in two. Coats with irregular lower edges are apt to be more becoming than straight-around coats. Coats that are slightly fitted or on the box order, give longer lines than those that are close-fitting and have a ripple peplum.

A COMPLETE COURSE IN DRESSMAKING

Avoid the too-short skirt and the skirt that is very full. They will both make you look shorter.

Top coats that have set-in sleeves and are belted at a low waistline with a narrow belt are far more becoming than a voluminous wrap or flaring unbelted coat.

Your hat is an important item. You are one of the women who can wear a small hat unless your face is round. Medium hats, too, will become you. *Avoid a shallow crown hat.* A hat with a medium high crown is better. A decided mushroom brim is another style which makes a person look shorter. On the other hand, a hat with an off-the-face brim or with the brim rolled on one side gives height.

If You Are Tall.—There is a difference in being tall and too tall. We know that Fashion designs for the tall girl or woman. She practically hasn't any clothes worries at all as far as the lines of the garment are concerned.

However, if you are too tall, I think I can give you a few helpful suggestions. First of all, how do you carry yourself? Don't on any account stoop, as if you were apologizing for being as tall as you are. To carry your clothes well you must stand up straight.

Of course you don't want to wear panels or stripes that emphasize your height—on the other hand, it's a mistake to make a dress

PRELIMINARY INFORMATION

with so many crosswise lines that look like a crosswise striped barber's pole.

Draperies are your share of the fashions that many other women cannot wear. Tunics, loose panels and coat effect are all good.

Avoid mannishly tailored clothes, they will make you seem larger than you really are. Don't be afraid to indulge in pretty clothes—blouses with frills and dainty collars.

Suppose we talk just about necklines. Have you ever happened to think that the neckline of a dress can make you look taller than you really are? I am thinking of those long V neck lines and the panel front effects that so many of the coat dresses have.

If you are wise you will leave these for your short plump little cousin. She needs them and you don't.

You can indulge in some of the ultra fashions—the boat and almond shaped neck that ovals slightly from shoulder to shoulder or the straight across Grecian neck line which many shorter women complain of as “trying.” Of course, there are square and oval necks, too, that will become you. Bertha effects, when they are in style, are a neck finish you may indulge in.

You may have your choice of either a kimono or set-in sleeve. A long, very close-fitting sleeve will make your arms seem long. Fancy sleeves will probably be more becoming.

A COMPLETE COURSE IN DRESSMAKING

I am going to put cascaded folds in a paragraph all by themselves. They are such a friend to the tall woman. Cascaded folds on a skirt, or a rippling cascaded fold from the shoulder to the hem, seem to be planned especially for the tall woman.

The tall woman's suit coat may ripple and flare. It may have a bulky collar, too, and plastrons of embroidery or large buttons for trimming.

And you women who are tall, capes are made for you. Evening wraps that are bulky and drape will become you. If you happen to like an unbelted, rippling back, top coat, you can wear it well, too.

In choosing a fur, you will do well to select a long-haired pelt. Remember that long-haired pelts are one of your special privileges, for only tall women can wear them well. Of course, short-haired pelts if made in a suitable style are often very becoming to a tall woman. Do not select so small a piece that it looks skimpy. You will look better in a broad scarf or a cape effect.

I have just a few cautions to add.

Perhaps you are tempted to flatten out your hair and wear low-crowned hats and flat-heeled shoes just to make yourself look a little shorter. Well, it really doesn't accomplish that result. It's far better to dress your hair becomingly, wear a hat that is just right

PRELIMINARY INFORMATION

according to the prevailing mode and shoes that have a good-looking medium heel.



Fig. (18) The thin woman will find frills are her friends.

If You Are Thin.—I don't mean slim. I am thinking of the women who describe themselves as painfully thin. Some people are naturally thin and have to face their clothes problem just the same as the stout woman has to face hers. You can't always cover yourself up to your chin, down to wrist and down to heels. Fashion won't let you do that every season. However, you can adapt the fashions.

Suppose we consider fabrics first. Has it occurred to you that crisp, hard-finished fabrics are trying? Take organdie, for instance. It will accentuate your thinness. On the other hand mull, or batiste, or even voile will give a soft effect that is very becoming.

Taffeta is another material you want to avoid. Crepe silks or charmeuse are really better.

It's the same with woolen. It's my advice to pass right by the mohair and poplin counter and purchase instead velour, French serge or wool jersey.

A COMPLETE COURSE IN DRESSMAKING

What you want in material is not a texture that is so harsh that it flares away in an abrupt line from figure, but a pliant weave which will fall into soft graceful folds. But avoid the clinging line that is another danger point.

It's a compliment to be called slim but never slinky. Don't be tempted to eliminate your petticoat because your top skirt is a heavy weave. A frilly camisole too, will make your silk frock and your sheer blouse set better.

High collars, of course, are very becoming but they are not always in style. If you are wearing a low neck, try adding a fold of cream color or white chiffon, batiste or net beyond the edge of the dress. It will soften the effect. You will also find neck frills or jabots very becoming.

On the other hand, a collarless neckline is severe. If the bones show a little in your neck, it will make the shadows under them seem deeper. If you are making a tailored cloth or silk dress, hunt out the styles with vest fronts. They give you a chance to add the becoming frill or two of net, batiste or lace.

One of the very best styles for the thin woman is a surplice waist.

Always see to it that there is a fullness at the waistline of your skirt.

PRELIMINARY INFORMATION

You can wear tunics and loose panels and draperies.

If you are thin and also young and the petite type, then ruffles are one of your privileges, too. There are many other nice things which I can tell you. Since you are thin, even if you are short, you can wear a cape gracefully. Bulky top coats too, will become you. Even a ripple is not out of the way on your tailored suit. If the coat has a flaring peplum or a little drapery, so much the better.

In hats you want to look for softness. If your face is thin, avoid the hat with sharp angles,—tricorns and hats that point out at the sides. The brim that droops a little will probably be more becoming. Handmade draped hats are excellent.

Avoid transparent blouses or dresses—especially in kimono styles. I'd advise, too, a skirt that is just as long as fashion permits.

After all, no matter what the latest fad is, the stylish thing to do is to dress becomingly. If you want to use a transparent material and perhaps in a kimono style sleeve, try making the sleeves of two thicknesses of the goods. This is often done. The same holds true of lace. If you are using lace for a waist or sleeves, line it with chiffon. Even skirt draperies of lace will seem softer if they are lined with chiffon.

A COMPLETE COURSE IN DRESSMAKING



Fig (19) For the woman who is older, there is becoming softness in surplice styles.

Are You an Older Woman?

—Whether you are growing older, from forty or fifty or sixty, there are certain changes in your figure. Perhaps you are growing stouter, either all over or through your bust or hips and abdomen. Perhaps your chest has flattened. You may not be quite so erect.

You will have to suit your clothes to your new figure. They can be just as charming but they will have to be different.

What you want are clothes that will do kindly things—soften the lines of your figure. There are only a very few older women who can wear severely tailored styles well. They are the broad-chested, straight-backed older women who always stand erect. As a general rule the middle-aged, or older woman, looks better in a one-piece dress or a semi-tailored suit that has a little trimming.

Three-piece suits, having a dress and suit coat are excellent. Or, if you make a blouse to match the color of your suit coat, and trim the blouse with a little suit material, it will look just like a dress.

Another way of making a suit into a one-piece dress is to cut the skirt off at the hips and attach it to a silk overblouse of a match-

PRELIMINARY INFORMATION

ing shade. When worn with cloth belt, it makes a very good looking, straight hanging dress for the older women.

Surplice waists are one of the becoming styles you may choose. Vests and long collars are also good. Avoid the very plain skirt. Tunic, panel and draped styles are better.

Always have a touch of white at the neck. It's far more becoming than a dark color next to the skin. Don't think that you have to have all your dresses high neck style—make some of them with pretty low V necks or the U-shaped neck outline and wear them with wet guimpes that have high collars.

Another way of making the neck look trim with a low neck dress is to wear an inch wide piece of black velvet around the neck. Make the ribbon to fit the neck and fasten it with snaps in the back or with small gold pins.

Coats of soft velour made with long shawl collar or revers and finished with a narrow belt are usually becoming to the mature woman. *The older woman will do well to avoid the extreme fads of fashion, for to be really becoming, her clothes must have a certain dignity.*

There is the question of the length of the skirt. Consult a full length peer glass when you are having the hem of your skirt turned. You will find a long skirt more graceful than a short one. It is impossible to give a general

A COMPLETE COURSE IN DRESSMAKING

rule for the length of skirt that will become every older women, but five inches from the floor usually is about right.

The width of the skirt is another point where the older woman must use her own good judgment, regardless of what is decreed by some French couturiere. A slip of a girl, who really hasn't very much figure, can wear an extremely tight skirt, but when you are older and have hips to consider, such a skirt is quite out of the question. However, there is no need to go to the other extreme and wear old-fashioned clothes. It's a fact that conservative, medium width skirts are in style season in and season out.

I might add a word about comfort, too. *Wear comfortable clothes.* No woman looks her best if her corsets are digging into her side and her collar chocking her, or her skirt whipping around her ankles every time she steps. Clothes you enjoy wearing are usually becoming.

This little rule applies to shoes as well as to dresses, coats and suits. Nine out of every ten older women look better in a comfortable straight heeled shoe or slipper, than they do in high French heels. Very high heels are apt to throw the body forward and out of its natural graceful poise. Naturally, an older woman tires easier and slumps into this unbecoming posture sooner than a young girl. *If you want to dress for an enduring smartness*

PRELIMINARY INFORMATION

that will last a whole afternoon or a whole day, wear comfortable clothes.

Pay particular attention to the head size of your next hat. Nothing spoils a woman's appearance quicker than a hat that is so large that it slips down over the ears or the too-small hat that rides perilously on the top of the head or slips rakishly over one ear. As a general rule, the older woman looks well in a hat that sits squarely on the head. Draped handmade hats are to be preferred to the severity of a blocked hat. The brimless hat is too hard for the older woman. A hat that shades the face a little is more becoming.

BECOMING COLORS

For the Blonde.

For the Brunette.

For the blue-eyed girl with brown hair.

For the auburn haired girl.

For the woman with gray hair.

If your complexion is sallow.

If your complexion is florid.

If you are stout.

For the Blonde.—Match up your eyes if you want a really becoming color scheme. Haven't you always heard that blue belongs to blondes? That's because blondes usually have blue eyes.

A COMPLETE COURSE IN DRESSMAKING



Fig. (20) Match your eyes, if you want a becoming color scheme.

You know, when an artist is studying color composition he learns that *a repetition of a different tone of the same color intensifies it*. So if your eyes are dark blue and you wear a pretty gray blue or peacock blue watch ribbon, for instance, with your navy blue dress, your eyes will seem bluer and more sparkling.

If you are very fair and have a clear skin and color, black will also become you. People with sallow complexions ought to avoid black, for it absorbs all light and doesn't give a pretty reflected glow to help out pale skin.

Of course, the blonde can wear pastel shades, almost any of them—pale blue, lav-

PRELIMINARY INFORMATION

ender, shell pink or light green. However, you will be wise to avoid yellow tones as they give too little contrast.

You must remember the importance of contrast in your cloth dress or suit. It is a great mistake for a blond to wear a sand colored suit or dress. If your hair is very light, dark shades will tone it and make it seem even more yellow. For street wear make your choice among the dark blues, dark browns, dark greens or black. Have a dash of color in the trimming—some becoming light shade. A soft silvery blue, for instance, on navy blue or brown is better for the blonde than the introduction of a vivid shade such as scarlet on navy or orange on brown. Leave these vivid contrasts for the brunette.

Another way of working up a becoming color scheme for a suit or top coat is to have the suit or coat dark blue and the lining hydrangea blue. It gives such a pleasing note of color when you open the coat.

In cotton frocks lavender or the medium and light shades of blue and green are the wisest choice for the blonde.

For evening the pastel colors, except yellow, are all good. White is also becoming to a blonde if it is combined with a touch of light color, such as blue.

For the Brunette.—As blue is the color for blondes, so brown is the color for brunettes,

A COMPLETE COURSE IN DRESSMAKING

ranging right through to orange and the copper shades. The one exception to this rule is the brunette with blue eyes. If you have dark hair and blue eyes probably you will find that blue becomes you.

Red is another shade that brunettes and only brunettes can wear successfully.

There are light shades a brunette looks well in but they must be more intense than the blonde wears. Here are some evening shades for the brunettes—greenish blue, on the turquoise order, apricot, peach, orange, lavender and flame.

Of course, dark brown is one of the best street shades for the brunette. However, it is by no means the only one. Brickish reds and the wine shades, which are now permissible as far as good style is concerned for the street, certainly help a brunette to look her best.

A brunette can also wear navy blue if she remembers to introduce one of her



Fig. (21) Browns are for brunettes.

PRELIMINARY INFORMATION

special secondary colors such as tan or orange.

If your hair is black, or a very dark brown, hunt out the reds in the cottons for your summer frocks. There are lovely red checked gingham, swisses and plain organdies. Cottons come in good looking brown tones too, which you can wear well. If you want something lighter, try a yellow or apricot organdie. Lavender is often becoming to the brunette, especially the lavenders that have a good deal of pink in them. You know there is a difference—some lavenders have more blue and some more pink. Remember that the blue lavenders belong to the blonde.

Black is not as apt to become a brunette as it is a blonde. However, if you have a very clear skin and lots of color you can probably wear it. It's a good idea to relieve it with a vivid touch of color, such as jade green or cerise. For instance, a black lace evening gown ought to have a sash of either shade.

The same rule holds true in wearing white. Use a vivid color to relieve it. *You need more intense colors than the blonde to bring out the coloring in your hair and eyes.* Although the reddish purples, which are sometimes called the fuchsia colorings, are rather trying, they are becoming to some brunettes.

For the Blue Eyed Girl with Brown Hair.—You are the in-between girl. Proba-

A COMPLETE COURSE IN DRESSMAKING



Fig. (22) There are colors which will help to bring out the pretty lights in your hair.

bly if you were named you would be called a “blondette.” Your coloring permits you to wear most the shades that a blonde wears and you can also have some of the brunette’s colors.

Of course, with blue eyes, blue in all its shades will be sure to become you. Since your hair is brown, dark brown shades ought to look well on you.

Perhaps you can carry out this little scheme and have both the coloring of your eyes and hair. With a brown suit and a white blouse try a narrow watch ribbon or neck bow of double-faced ribbon—brown on one side and gray blue on the other.

PRELIMINARY INFORMATION

You really have a wider choice in colors than either the real blonde or the real brunette. Take your street dresses and suits for instance. Since your hair is fairly dark, you can wear the light tan which is taboo for the yellow haired girl. On the other hand, for evening, you can wear a pastel shade if it happens to take your fancy.

But to go back to street clothes, you have your choice of tan, brown, dark blue or any of the pretty reds that happen to be worn. If you are blessed with a good color and a fair skin, then you can wear a light gray. If your skin is sallow, taupe, which is gray with a little brown in it, will be more becoming. Whether or not you can wear black depends on your skin. If you have a clear skin, you will probably look well in black.

Where your costume is either white or black, try to introduce a note of color, such as hydrangea or peacock blue. It will make your eyes seem prettier, you know.

In cottons, the soft gray blues will probably be your wisest choice. Remember that you can wear the bluish lavenders too, and yellow will intensify the lights in your hair and not detract from it.

Light shades for evening will probably suit you better than vivid shades. Lavender, light blue, light green or yellow are all good.

You will find it a good rule not to wear the too vivid shades. It takes a real brunette

A COMPLETE COURSE IN DRESSMAKING

to carry off a whole gown of flame color or peacock blue. With your coloring, you cannot stand more than a touch of these colors in the trimming. On the other hand, the colorings of your hair, eyes and skin are too intense for the very palest of pastel shades. You will have to study the degree of color that you choose.

You need more intense shades than the blond, but not as vivid as the brunette can wear.

If Your Hair is Auburn.—What you need is contrast, but not a vivid contrast. Let your pretty hair be the interesting spot of color.

Black will do wonders in bringing out the beauty of auburn hair.

If your eyes are blue, you will wear dark navy blue well. However, avoid the light or vivid shades of blue. Being what is called a complementary color to red, they intensify it. A vivid blue will make your hair seem a more brilliant shade and you don't want that.

There are many neutral shades for street wear that will become you among the grays and taupes.

A very dark greenish brown is also good, but a reddish brown is seldom becoming. It's too near your own colorings. Of course, the same holds true of red. Green, except, the very darkest shades, come under the rule of too great a contrast.

PRELIMINARY INFORMATION

The auburn haired woman may safely choose any of the darker shades of blue for her cotton frocks. There are lovely grays, too, in gingham, organdie, linen and batiste that she will look well in. Tan if it isn't too red, is becoming. The auburn haired woman always looks well in white. If there is any color introduced in the white frock for day-time wear, it must be subdued, as for instance, a cluster of silk flowers or fruit in tones of dull gray blue and lavender on a white frock.

Some auburn-haired women wear certain shades of blue lavender well but you want to select it carefully. Under no circumstances wear a red lavender. You know it varies.

Even for evening the auburn-haired woman is wise to select a black gown—black lace or net—or if you are very young, black taffeta.

All white, of course, is always becoming or you may have a vivid contrast with it for evening as a turquoise blue or a jade green girdle of ribbon or tulle. Such decided contrasting colors can be used for evening if they are not placed too near to the hair.

There are lovely gowns, too, of gold lace and gold cloth and brocade which are becoming to a woman with auburn hair.

If You Have Gray Hair.—Certainly if your hair is gray, you ought to have no difficulty finding pretty clothes. There are so many, many lovely shades that seem to be intended for the woman with gray hair.

A COMPLETE COURSE IN DRESSMAKING



Fig. (23) The gray haired woman will do well to remember the becoming touch of white at the throat.

There used to be a time when a woman grew a little older that she gave up all the pretty colors and wore only gray and black. But they don't do that any more.

Did you know that a very light and soft shade of pink is just about the most becoming color you can wear? You might have a nice little informal dinner dress of pink chiffon or a pink silk skirt with a matching color chiffon blouse. Such a skirt and blouse topped with a becoming sweater, perhaps of light gray wool, make a smart costume for out-of-doors in the summer.

Blue, orchid and lavender shades go prettily with gray hair, too. There are also soft shades of light blue which are becoming. But don't use very much of the blue. Just an edge of gray blue and silver ribbon showing beyond the neck edge of a navy blue frock will tone it attractively.

For street wear you have quite a variety from which to choose. Navy blue, gray, henna and neutral shades such as taupe.

If your skin is clear and you have good color you can wear black well.

In cottons, there are lovely flower sprigged dimities in gray and blue tones which are

PRELIMINARY INFORMATION

becoming to an older woman. Gray swiss dotted in blue is another good choice for the gray haired woman. Black and white effects too in voile, dimity, and swiss are considered very smart.

For evening, an older woman may choose a pastel shade of gray blue or lavender and be dressed in perfect taste. Gray chiffon over a silvery blue chiffon makes an exquisite dinner dress. Brocades come in lovely shades of gray blue and lavender too, for evening. As I said before, you can wear black if your skin is clear, and of course, black is always nice for evening. The older women's evening gown, black and silver is a dignified combination.

If Your Complexion is Sallow.—As I said before avoid black. It absorbs all color and doesn't give a reflected glow to help out a pale skin.

Neither is it a good plan to wear brown or yellow tones. As they intensify the yellow tinge of the skin.

It will probably surprise you to know that you can wear a peach shade which has pink and yellow in it and your skin will look whiter. It's just a curious little fact about color. *If you place a color that has two shades in it along side of one of the shades the two like shades will seem to disappear.*

It is true that colors do very definite things. *Colors which are opposite each other*

A COMPLETE COURSE IN DRESSMAKING

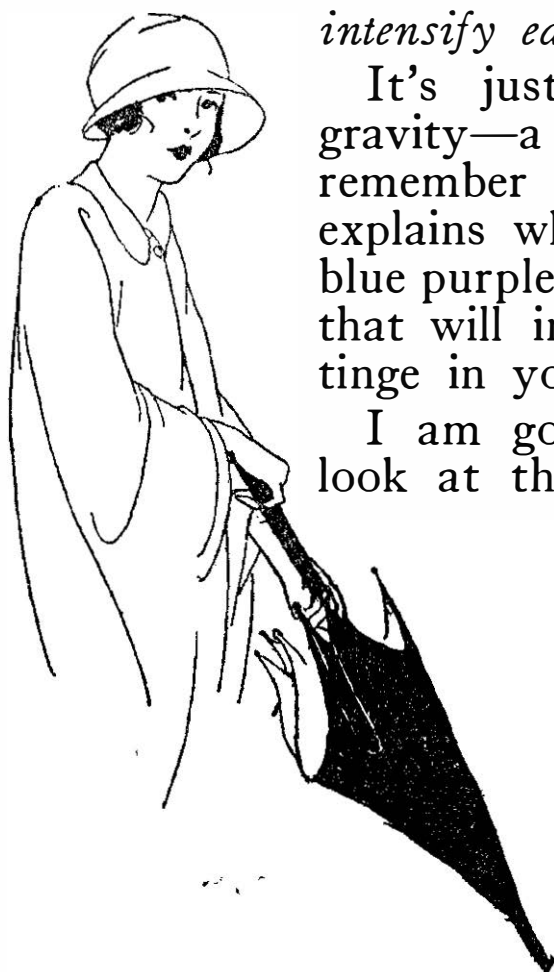

Fig. (24) A red umbrella will do wonders in the way of lightening up a sallow complexion.

on the color wheel, see Fig. (26), intensify each other.

It's just like the law of gravity—a fact we have to remember and accept. This explains why you can't wear blue purple. It's another color that will intensify the yellow tinge in your skin.

I am going to ask you to look at the color wheel, Fig. (26). You will see that blue purple and yellow are opposite each other. Read the colors that are opposite each other. You will probably recall having seen some of the opposite colors together, and that they did intensify each other.

Neutral tones are your safest choice. A taupe dress with the vest edged with the tiniest bit of old rose and gold ribbon ought to look well or you might have a gray dress with a touch of henna. Probably on all henna dress would prove very becoming. *Remember the importance of a touch of cream color or white at the neck.*

PRELIMINARY INFORMATION

Just about the best rule a woman with a sallow complexion can follow is to look for warm rosy tints. If you choose brown, hunt out a warm reddish brown. A greenish brown is to be avoided. A navy blue that is a red blue, not a greenish blue, will become you if you touch it up with a little rose trimming—perhaps it will only be a placque enameled in rose, worn on a silk cord. Rose or henna wool embroidery is an effective way, too, of introducing the needed color.

For a dinner dress or evening dress, you will do well to make your choice a subdued rose shade as gray or taupe chiffon over rose chiffon. Another way of bringing in the rose tint in such a frock is to bead a gray, a navy blue, or a taupe chiffon with rose crystal beads.

When you are choosing accessories to go with your street clothes, remember that a rose tint will seem to bring a becoming glow to your cheeks. Perhaps you can wear a creamy old rose wool scarf with your tailored suit. Or you may be able to tuck a rose-colored flower on the brim of your hat. Even a rose colored pocket handkerchief will help out a drab costume.

Another item which has its importance so far as color is concerned is your umbrella. I hope it isn't green. Really there is nothing so trying for the woman with a sallow complexion as a green umbrella. It even robs

A COMPLETE COURSE IN DRESSMAKING

a rosy cheek of all its color. Navy blue isn't especially good, either. And black never adds to your appearance. If you want to look your very best in the rain, choose a red umbrella, or a reddish brown one.

If Your Complexion is Florid.—Sometimes I think the woman with a florid complexion has just about the most difficult problem in selecting becoming clothes. Perhaps you have had the experience of selecting a frock and trying it on when your face wasn't flushed, and it was becoming, and then you wear it your face flushes up, and it isn't becoming.

You can't trust your complexion, so you will have to go more by rule.

No doubt you already know that you can't wear red—that red reflects red in your face.

It may be too that you have learned from bitter experience that blue green makes your face more florid. Does it puzzle you? If you will look at the color wheel on page 67 you will find it's opposite red and therefore what is called a complementary color. Not because we know the reason why, but because we have to accept the fact—*complementary colors intensify each other.*

However, if you wear purple, it will lessen the color of the skin for purple is made up of red and blue. The two like shades will

PRELIMINARY INFORMATION

disappear. I have explained the reason for this in my suggestions for a Sallow Complexion.

Black is excellent for you for it absorbs all light and doesn't reflect color in your face. As a matter of fact, it will seem to take away some of the color from your face. The same is true of very dark shades of brown and green as they absorb nearly all color.

The neutral shades such as taupe, dull gray, blue, and gray lavender, you can wear, as the gray tones them down.

In neck wear, you will find a cream color more becoming than dead white, which offers such a decided contrast to your skin. I might add that all white is not as becoming to the woman with a florid complexion as shades which neutralize the color in her face.

Your very wisest choice in an evening gown will be black. Don't be tempted to relieve it with a brilliant dash of color. It will prove far more becoming combined with a little cloth of silver or gold, or a few subdued flowers in dull blue and lavender tones.

I want to add a bit of caution about your umbrella. Don't be tempted to buy a red umbrella. Even in the rain you won't need the reflected red glow of it in your face. There is the question of the green umbrella, too. You certainly don't want to bring green

A COMPLETE COURSE IN DRESSMAKING

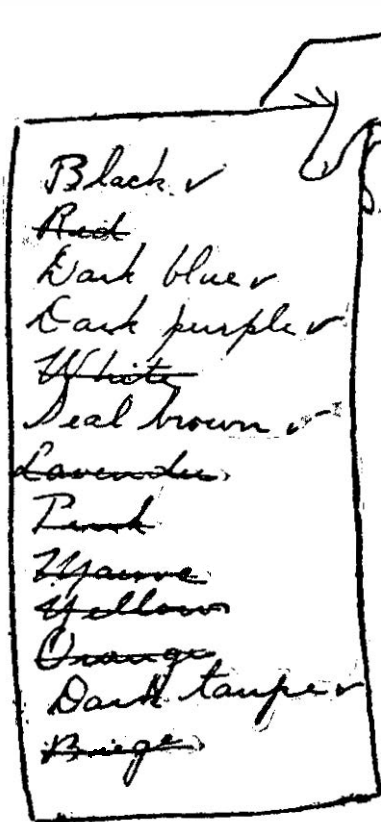

Fig. (25) If you are stout, cross the vivid, the light shades and white off your shopping list.

so near your face. Black or dark blue is a better choice for you.

If You Are Stout.—How much thought have you given to color. Just the mere lines of a dress won't make you look slimmer if the color is wrong.

It's the inconspicuous colors that will make you look smaller. Black absorbs all light and is by far

the most slenderizing shade you can choose, if black can be called a shade.

White, which does just the opposite, reflects all light, will make you appear larger.

Neutral shades, such as gray and taupe, are excellent for they blend in with the surroundings and are most inconspicuous.

Dark shades of brown or blue are permissible. Avoid any bright or light shade, as it will call attention to your size.

Take an inventory of your wardrobe and see how many light dresses you have. Per-

PRELIMINARY INFORMATION

haps it hasn't occurred to you that there are just as many pretty dark cottons as light ones. Voiles, linens, and crepes all come in dark shades now. As a matter of fact, dark cottons are considered smart.

You can always lighten them up, you know, with white at the throat, and perhaps in a vest front.

I might speak about color in trimmings, too. You may indulge your liking for brightness in trimmings if you choose, but be careful where you place the bright spot. As a matter of fact, it's better to make it a narrow piping or binding than a spot. An edge of bright red or green or peacock blue to outline a vest front, to finish the sleeve, or across a collar is quite permissible, and often the stylish touch to the garment. However, it is not advisable to sew a bright piping crosswise on the garment or to outline a large piece. Keep your piping running up and down for the best effect.

COMBINING COLORS

It is not just luck that colors look pretty together—neither is combining color a gift which some people are endowed with and some people are not.

When you come right down to the facts, it's a little problem that has to be learned just like the multiplication table, only in

A COMPLETE COURSE IN DRESSMAKING

this case instead of learning that two times two makes four, you learn where the colors are placed in a color wheel and their relation to one another. See Fig. (26). To tell the truth, the rules are easier to remember than lots of the things we had to memorize back in the grades.

It's just as important for the person planning a dress to know these rules as it is for the artist planning a painting. Both are planning a composition in color. If you know the rules, you won't make a bad color composition. There won't be any jarring notes in your costume. You won't have that element of doubt as to whether you ought to add a certain color note.

The Color Wheel—For convenience sake, when an artist is studying color composition, the colors are placed on what is called a color wheel. See Fig. (26). The wheel is a circle divided into parts, and a color painted on each part or the name of it written there. There are rules regarding the placing of the colors on the wheel, and laws regarding the relation of one color to the other. Colors have certain definite effects on one another when placed close together or overlapped.

Sometimes only the primary colors of the spectrum, red, green and violet are placed on the wheel. However, for dress designing, it is more practical to include the in-between shade as in Fig. (26).

PRELIMINARY INFORMATION

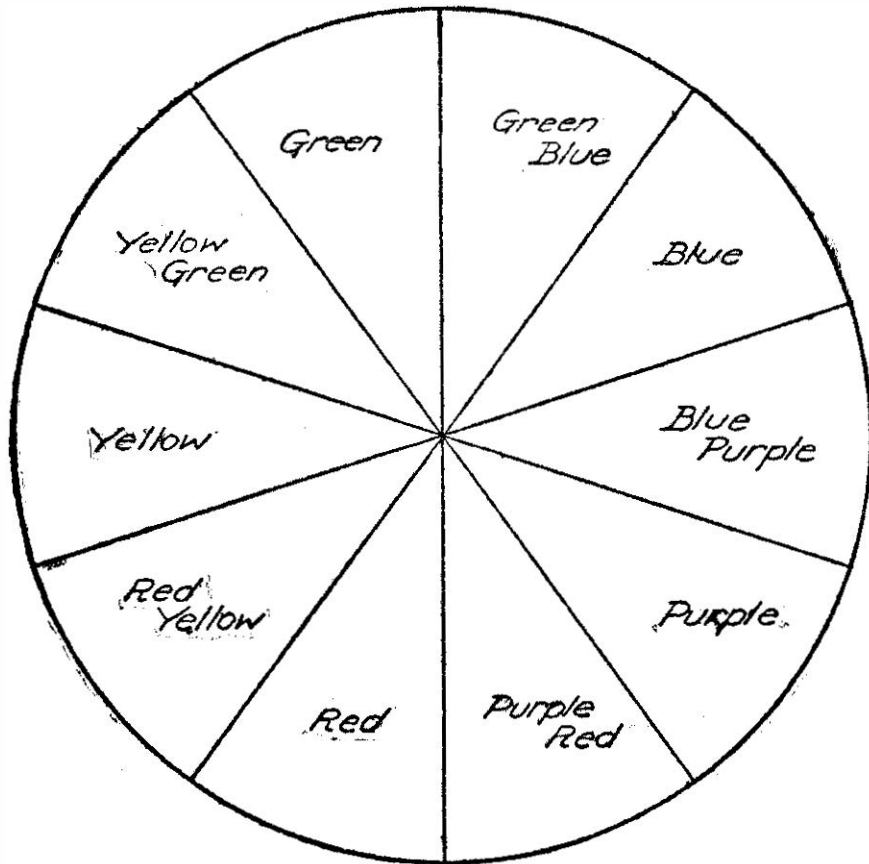

Fig. (26) Here is the little color wheel that will help you choose colors that go together.

The colors are placed on the wheel with what are called complementary colors opposite each other.

Complementary Colors.—A colored object shows a certain color by absorbing part of the light rays and reflecting part of the light rays. For instance, we know that light consists of the colors of the spectrum, red, green and violet. If an object is red, it absorbs the green and violet rays, and reflects only the red rays of light. Therefore, green

A COMPLETE COURSE IN DRESSMAKING

blue which is a combination of green and violet is the complementary color to red or the shade which is absorbed by a red object.

That a red object really absorbs this shade has been proven by tests. Also the other complementary colors have been determined.

Learn the complementary colors:

Red—green blue.

Red yellow—blue.

Yellow—blue purple.

Yellow green—purple.

Green—purple red.

Make a color wheel for yourself, and place the complementary colors opposite each other.

Those opposite each other on the color wheel (complementary colors) can be combined—as blue and red yellow (orange). Of course you must remember this in making clothes—have one predominating color and just a touch of the other for trimming if they are direct opposites as in this case.

The second rule is that you can combine colors near together on the wheel as blue and blue green (turquoise).

The third rule is that you can use different degrees of the same shade together as navy blue and copenhagen, or brown and tan.

The fourth rule is that you can use three colors together which are about an equal

PRELIMINARY INFORMATION

distance apart on the wheel as yellow green, blue and purple red. Here, too, have one color dominating and the other to supplement it. Probably such a combination would be used on the light tones of these colors. For instance, the bodice and drop skirt of a dance frock may be lavender, with overskirts of light yellowish green and blue tulle.

The fifth rule concerns black, gray and white. As black is a combination of all the colors in their full intensity, it can be used with any one of them. Gray is also a combination of all or several of the colors and can be combined with other shades. In gray material one color is apt to be in evidence. We have blue grays, pink grays, brown grays, etc. In combining gray with blue, use a bluish gray, not a pink gray. White is the absence of all color so it can be used with any shade.

These rules have to be followed most explicitly where the colors are intense or vivid. *Where colors are dark, that is, have black or the complementary color mixed with them, you can be more lax in combining them with other colors without striking a jarring note. The same thing holds true where light shades are used, more white being added to them. The whole rainbow of pastel shades can be used together in perfect harmony.*

Caution must be exercised in using colors in their full intensity, as scarlet, emerald

A COMPLETE COURSE IN DRESSMAKING

green, electric blue, etc. A child or a savage revels in violent and garish colors, while refined people instinctively choose the subdued tones. Large amounts of violently contrasting color are never beautiful.

It is well to remember that reds and yellows are affected more by artificial light than the violet and blue shades. Often, red or yellow will seem to change its shade under an electric or gas light.

Here are a few examples of the applications of the different rules:

1st: You know that blue and scarlet are complementary colors. The correct combining of these two shades might be expressed in a dark navy blue serge or twill dress. Suppose the dress had a deep V opening in the front, narrow revers, and a small collar. If the revers and collar were piped with a very narrow strip of scarlet (not more than a cord) and then a sheer batiste or net over-collar and vest added, so far as the color was concerned, the dress would be perfect.

However, if instead of the piping you used a broad band of red goods, the effect would be garish. It is never wise to use complementary colors both in their most brilliant shades unless they combine to form the smallest motif on the dress, as bright blue and red interwoven with dark blue embroidery on a dark blue dress.

PRELIMINARY INFORMATION

2nd: One often sees the application of rule 2 concerning the combination of colors near together on the wheel. Just in the way of an example, we might consider the fuchsia colors which are purple and a purple red (cerise). This can be beautifully worked out in an evening cape, using purple velvet for the outside of the cape and then cerise silk veiled with purple chiffon for the lining.

3rd: You have probably applied time and time again the third rule—using different degrees of the same color. A brown linen dress embroidered in tan wool yarn is a pleasing example of this rule.

There is only one danger in applying the rule. Make sure that your two shades of blue or red or green aren't mixed with different colors, as a yellow green and blue green. If the dark shade is yellow green, and the light shade a blue green, they won't look well together. On the other hand, a dark blue green and a light blue green will harmonize perfectly.

4th: Three colors about an equal distance apart on the wheel will harmonize, too. Of course, they ought not be used in three areas of equal proportion. An example of a correct combination of this kind is a dark blue chiffon dress beaded in a paisley design with purplish red, yellow and black beads.

5th: Black, gray or white can be introduced into any color scheme. The becoming-

A COMPLETE COURSE IN DRESSMAKING

ness of a white collar on any dress is a proof of this. You have probably noticed, too, that an edge of black braid seems in keeping with a green, a blue, a red, or a purple dress.

Colors darken as they have more black added to them, and lighten as they have more white added. If sufficient black is added to darken the colors considerably, any of the colors can be used together, as the black neutralizes them. The same is true if white is added until colors are a pastel shade. *All the colors of the spectrum in pastel shades are in perfect harmony.*

YOUR SEWING MACHINE

Sewing machines differ somewhat in their construction, but a few rules apply to all of them:

Do not let the machine stand open when you are not using it. Dust will clog it. Keep a muslin cover to throw over the machine when you do not want to remove the work.

Oil your machine at night—a freshly oiled machine is apt to soil the work.

Clean the machine at least once a month, wiping it free from lint and dust.

Do not run your machine with the presser foot down, unless there is material under it. If the presser foot rests on the feed, it will wear out the feed.

PRELIMINARY INFORMATION

Do not run your machine threaded before placing your material. The thread will clog and break.

Remember that you cannot pull the material faster than the machine feeds. Guide the material, but do not pull it or you may bend or break the needle.

REGULATING THE TENSIONS

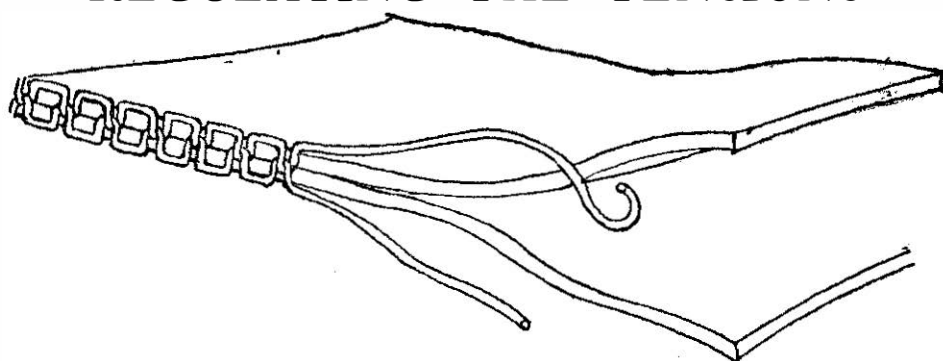

Fig. (27) If the tensions of your machine are adjusted correctly, the stitches will lock in the center.

On a lock stitch sewing machine, if the tensions are properly regulated, the thread links in the exact center of the fabric. The stitch on the right and wrong side of the goods will look identical. See Fig. 27.

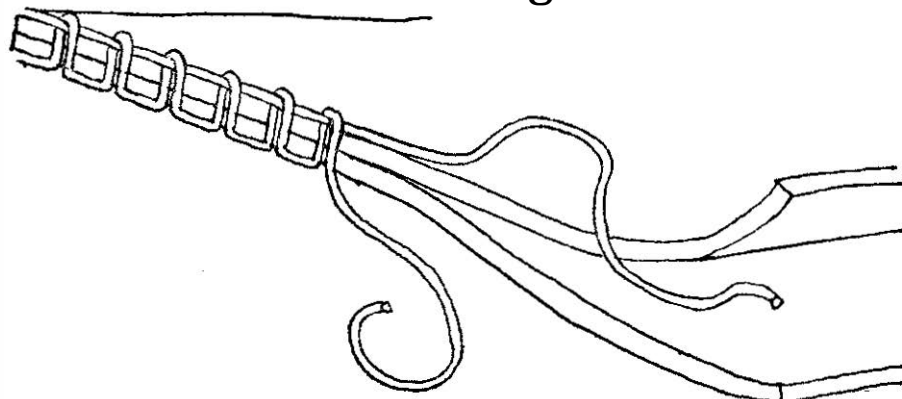

Fig. (28) If the needle tension is tight, the thread lies flat on the upper surfaces.

A COMPLETE COURSE IN DRESSMAKING

If the tension on the upper thread is too tight, or the bobbin thread too loose, the upper thread will lie on the surface of the goods. See Fig. 28. The thread is apt to catch and pucker.

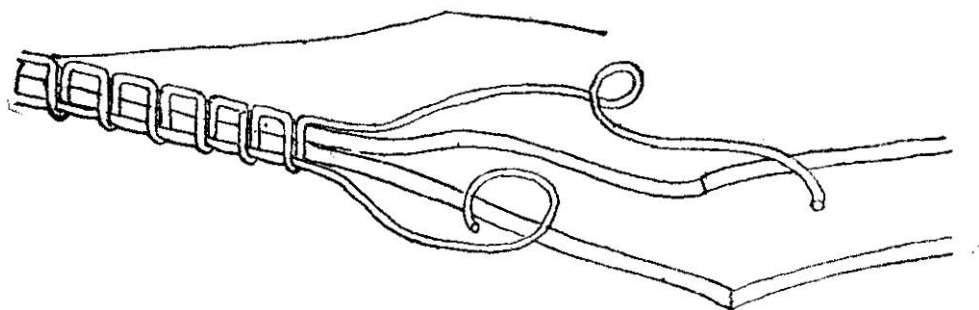

Fig. (29) *If the bobbin tension is tight, the under thread is straight.*

On the other hand, where the bobbin thread is tight or the upper thread too loose, the reverse happens, and the thread on the under side (next to the feed) will appear straight on the surface. See Fig. 29. This does not make a pretty stitching, and the thread is apt to pucker. However, it makes a stitching that is easy to rip. Try it sometime, when you are just testing the fit of a garment.

Once the bobbin tension has been properly adjusted, it will need but little change. *Usually the tension can be suited to different materials by changing the needle tension.*

Always test the tension and length of stitch before starting to stitch the garment.

The Pressure on the Material.—Do you ever regulate the pressure of your sewing machine foot? There should be just sufficient pressure to prevent the goods from raising with the

PRELIMINARY INFORMATION

needle. On very sheer or flimsy goods, increase the pressure. On extremely thick goods, lessen it.

If your machine is running hard, look at the presser foot. There may be too much pressure.

Turning a Corner.—Run the stitching to the exact corner. Stop the machine with the needle in the goods. Raise the presser foot, turn the material so that it is in the correct position for the next stitching, lower the presser foot, and stitch.

PROPER THREAD AND NEEDLES

It is important that you use the right thread and the right needle for the material; that is, if you want your machine to run easily and to have really good work. The needle must suit the thread, too. Here are tables for reference:

A COMPLETE COURSE IN DRESSMAKING

MACHINE NEEDLES AND THREAD

Material	Size of Needle	Sewing Cotton Sewing Silk
Mull, chiffon, etc.	Very fine needle No. 9	100 to 150 cotton 00 or 000 sewing silk
Voile, very fine linen or silk goods	Medium fine needle No. 11	80 to 100 cotton 0 sewing silk
Shirtings, fine ging- hams, and medium weight silks	Medium machine needle No. 14	60 to 80 cotton A or B sewing silk
Coarse gingham, light weight woolen goods or heavy silks	Medium coarse machine needle No. 16	40 to 60 cotton C sewing silk
Denim or coatings	Coarse machine needle No. 18	30 to 40 cotton D sewing silk
Heavy woolen tickings, khaki cloth	Very coarse machine needle No. 19	24 to 30 cotton E sewing silk 60 to 80 linen thread

NEEDLE AND THREAD FOR HAND SEWING

Material	Size of Needle	Sewing Cotton Sewing Silk
Mull, chiffon, etc.	No. 10 to No. 12	100 to 150 cotton 00 or 000 sewing silk
Voile, very fine linen or silk	No. 9	80 to 100 cotton 0 sewing silk
Shirtings, fine ging- hams, and medium weight silks	No. 7 or No. 8	60 to 90 cotton A or B sewing silk
Coarse gingham, light weight woolens or heavy silks	No. 6	40 to 60 cotton C sewing silk
Denim or coatings	No. 4 or No. 5	24 to 40 cotton D sewing silk
Heavy woolens, tick- ings or khaki cloth	No. 1 to No. 3	8 to 24 cotton E sewing silk 60 to 80 linen thread

PRELIMINARY INFORMATION

SEWING MACHINE ATTACHMENTS

Are you really acquainted with your sewing machine? Do you know how to use all the attachments? Do you know everything that each attachment will do? Run over the list and see if you know how to use the following attachments:

Narrow hemmer

Wide hemmer

Binder

Tucker

Ruffler

Edge stitcher

Corder

Quilter

Narrow Hemmer.—This attachment is merely another kind of a sewing machine foot. The foot of the machine is removed and the hemmer is put on in its place.

It is possible to do several things with a narrow hemmer. If you are using this attachment, it isn't even necessary to crease the edge in order to turn a narrow hem. Just guide the goods and as it feeds through the foot, *the edge is rolled and stitched at one time.* See Fig. 30.

It is excellent for hemming a cuff or a trimming piece. It does not work well on curved edges.

A COMPLETE COURSE IN DRESSMAKING

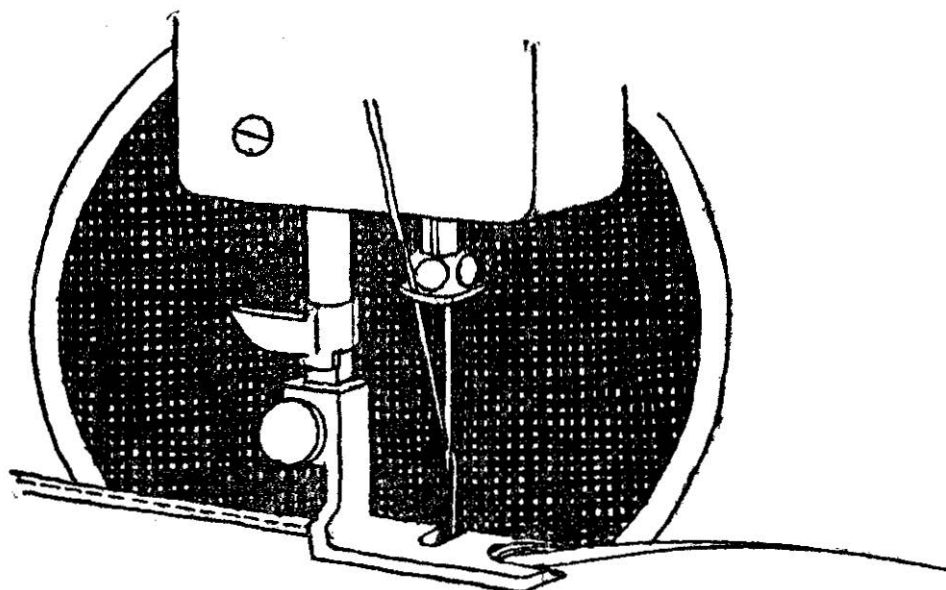

Fig. (30) A narrow hemmer folds and stitches the edge automatically.

The goods must be removed from the hemmer at a corner.

Lace can be joined to the edge at the same time that the edge is hemmed. Slip the lace in

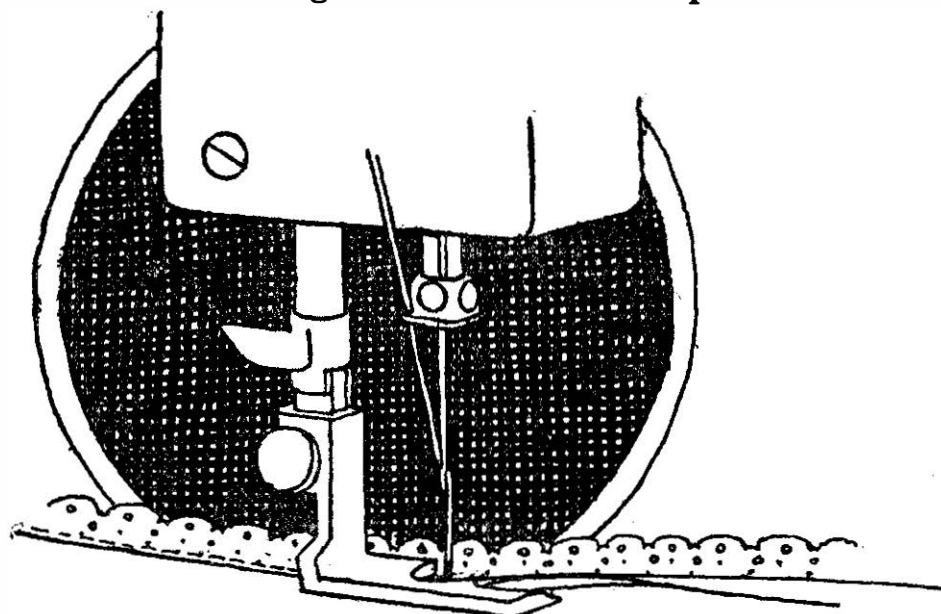

Fig. (31) You can hem an edge and sew on lace at one time.

PRELIMINARY INFORMATION

next to the thread and the one stitching will do all the work. See Fig. 31. It can also be used for setting in insertion, handling the insertion the same as the lace.

The neatest kind of a lapped felled seam can also be made with this attachment. Place the two pieces to be joined one on top of the other under the hemmer with the underpiece extending a quarter inch beyond the edge of the upper piece, and stitch. (Here the edge of the material is not turned under.)

Open up the two pieces of the material and hem the free edge of the under piece.

Such an attachment is invaluable in making underwear, blouses, men's shirts and children's clothes. As you progress with the lessons, you see innumerable ways of applying it. Learn how to use the narrow hemmer for your machine now.

The book of instructions that comes with every sewing machine will tell you just how to adjust it to your particular machine.

Wide Hemmer.—This attachment is adjusted at the side of the foot.

Instructions for adjusting the hemmer comes with every sewing machine.

I add just these few suggestions. Pull the goods back and forth in the hemmer until the hem is turned properly. Then stitch, guiding the material so that the hemmer is always full. See Fig. 32.

A COMPLETE COURSE IN DRESSMAKING

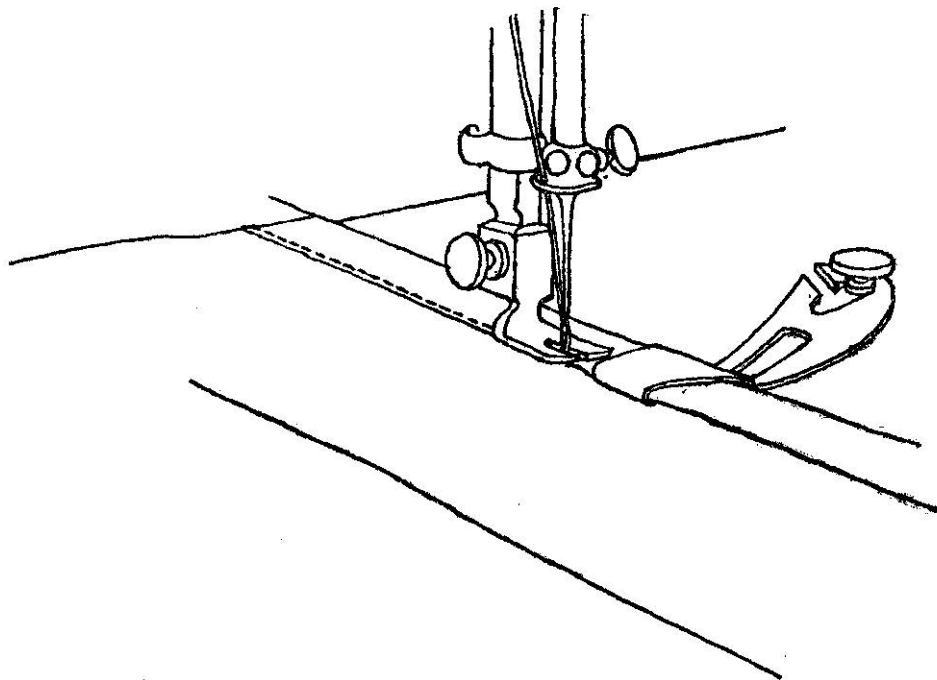

Fig. (32) Its easy to hem cuffs, the fronts of a waist, a little girl's skirt or a straight ruffle, if you have a wide hemmer.

The wide hemmer will work only on straight edges. It is a great convenience in hemming sheets, making underwear, children's clothes, wash dresses and blouses. Just in the way of an example, there is the center front closing of a waist, and the hem at the top of the turn back cuffs. Perhaps you have planned your work so that you are making several blouses at one time. With the wide hemmer you can roll and turn the edges and finish all these pieces in a few minutes.

In making a garment or garments where you expect to use the wide hemmer, place all the pieces that need hemming in one bundle, and run these through the hemmer before closing the seams. It will facilitate the work.

PRELIMINARY INFORMATION

The hemmer works better when the pieces are flat, and if you run them through all at one time it saves taking the hemmer on and off the machine.

Binder.—Another time saving attachment is the binder. It is a scroll shaped piece of metal which sometimes attaches like a presser foot or in other machines screws to the side of the regular foot.

Draw the bias strip of material through the scroll and under the needle. Insert the edge to be bound between the two thicknesses of the bias and stitch. See Fig. 33.

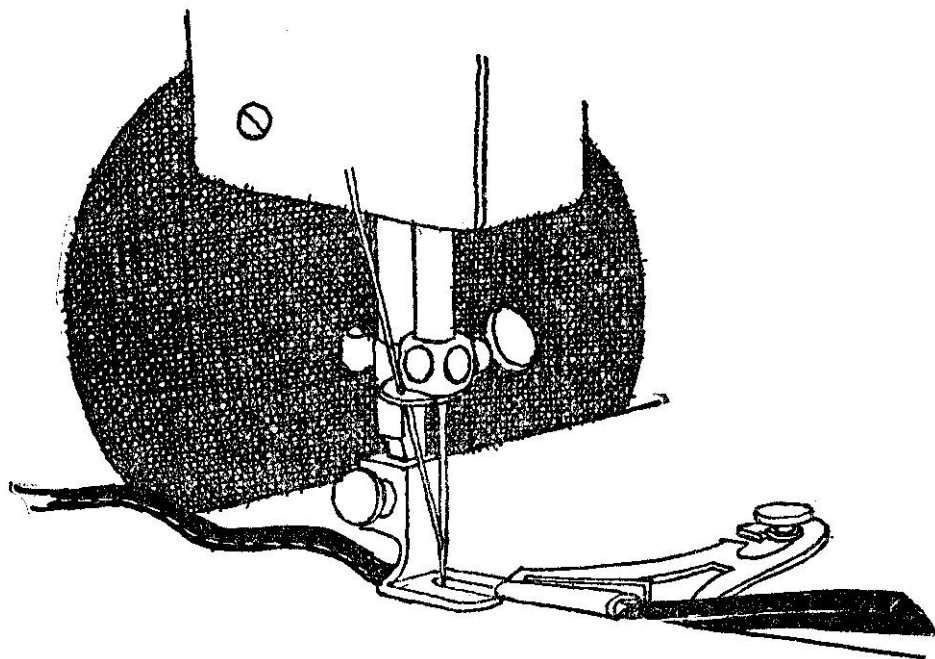

Fig. (33) There is no hand folding when you use a binder.

Think how simple it is to make a house-dress when you can bind the edges with just one stitching. There is no folding or pressing either of the bias to prepare it. Bias bindings

A COMPLETE COURSE IN DRESSMAKING

make a pretty trimming, too, on children's gingham, percale and chambray frocks.

Tucker.—There is no tiresome measuring and marking for the widths between the tucks or the width of the stitching if you use a tucking attachment. The attachment is adjusted to the machine the same as a presser foot. There are gages you can set to regulate the width of the tuck and the width between the tucks.

Crease the material and stitch as shown in Fig. 34. The attachment marks where the next tuck is to be creased.

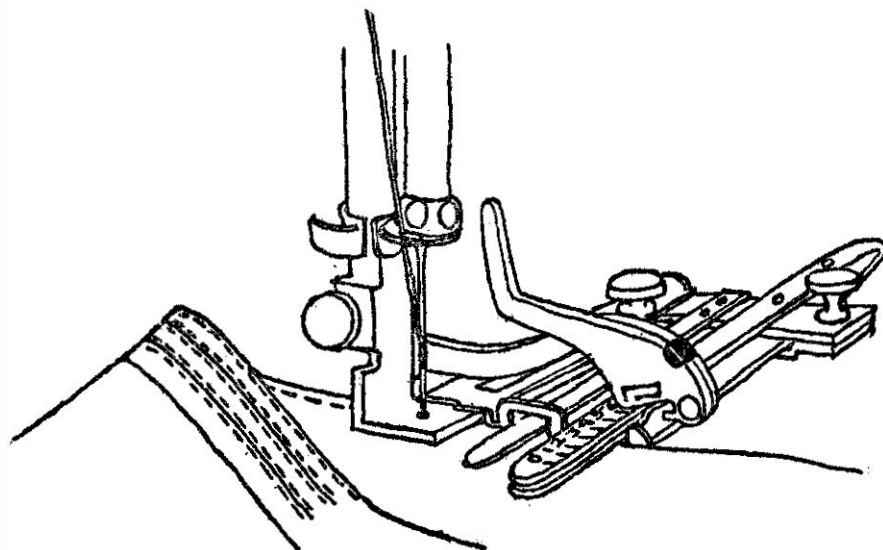

Fig. 34 A tucker is a great convenience when you are making underwear or summer dresses.

One point you must remember in using a tucker is to form the tuck on the straight thread of the goods. It is almost impossible to tuck a bias.

You can have just as many pin tucks in your summer organdies and dimities as your

PRELIMINARY INFORMATION

heart desires if you learn how to run your tucker. And think how much prettier you can make your blouses and children's clothes with the addition of tucks here and there.

Ruffler—How many hours have you spent running in gather threads? Of course, there are places where nothing else will answer for the gather thread. But how about the ruffles and frills? You can run them through a ruffler in just about three minutes and do away with an hour's hand work.

There is a ruffling attachment which comes with nearly every sewing machine. Take out yours now. It is just the matter of a couple of thumb screws to adjust it. Place the material between the two blades of the ruffler and stitch as shown in Fig. 35.

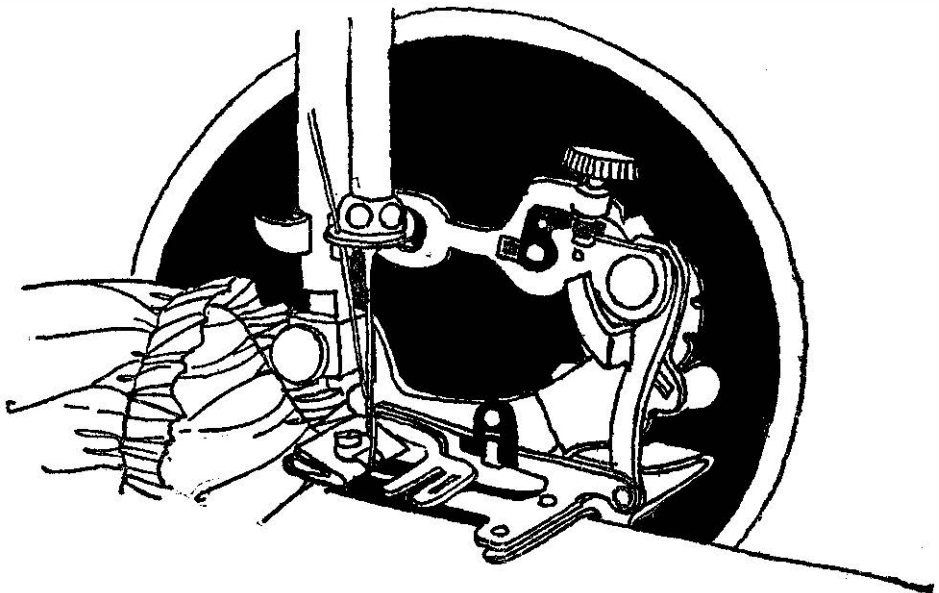

Fig. (35) Use a ruffler and do away with handrun shirr threads wherever you can.

A COMPLETE COURSE IN DRESSMAKING

If it's a petticoat ruffle that you are gathering, you can sew it to the bottom of the petticoat and sew on a bias at the same time, by laying the ruffle on the right side of the petticoat and inserting the bias as in Fig. 36.

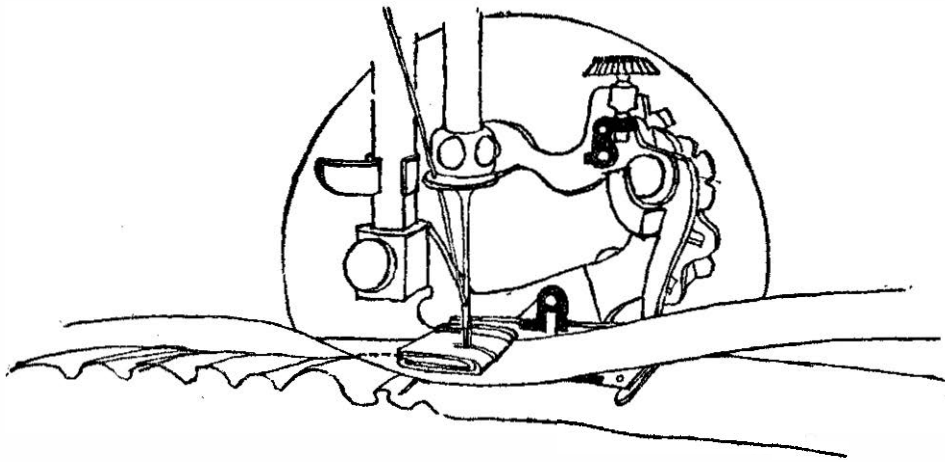

Fig. (36) Joining the ruffle to the lower edge of a petticoat.

After the petticoat is removed from the machine, turn the ruffle into its finished position, fold under the free edge of the bias, and stitch a second time, using the regular presser foot.

Edge Stitcher.—The name almost tells the story—an edge stitcher is for joining lace. If you are making underwear or children's clothes or dainty summer dresses it is almost indispensable.

The lace is placed in the attachment as shown in Fig. 37. All you have to do is guide it and the attachment laps one edge over the other and the needle stitches through both pieces of lace.

PRELIMINARY INFORMATION

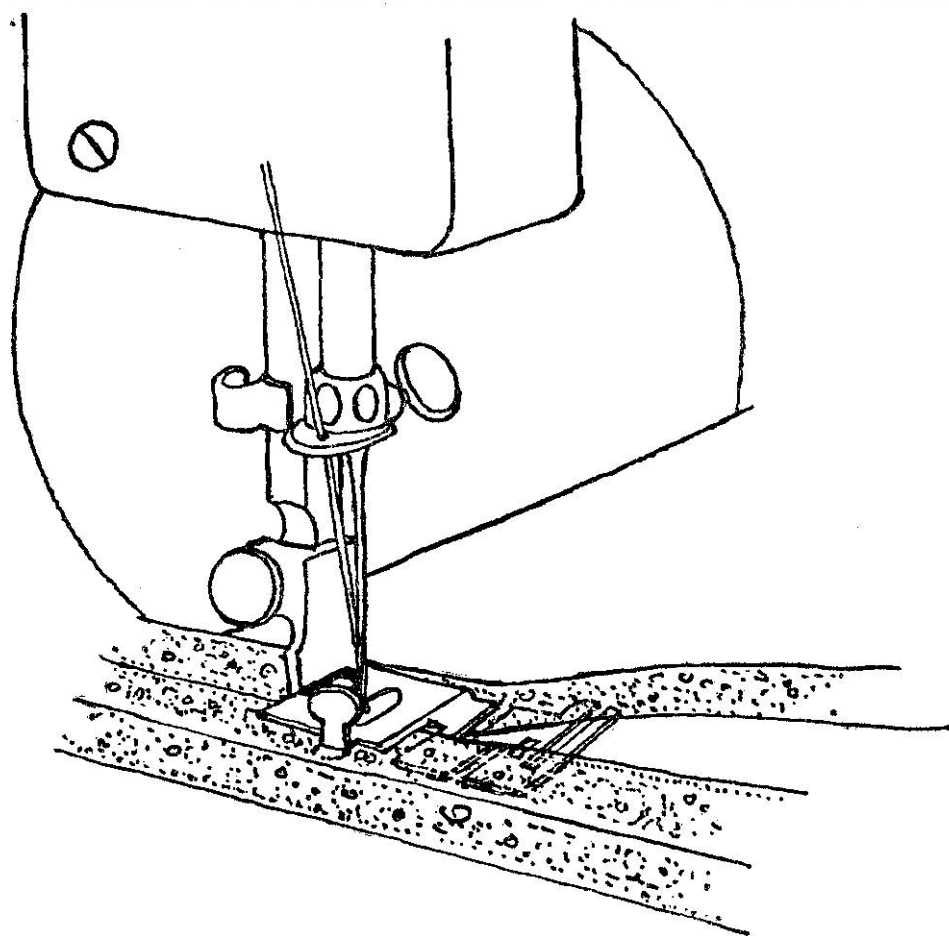

Fig. (37) An edge stitcher joins lace quickly and neatly.

The edge stitcher can be used for joining narrow bias trimming folds to the material, too. Or, you can use it for sewing on ribbon. It will keep the stitching true to the edge.

Cording Foot.—Of course, you know that you can't stitch cording with an ordinary sewing machine foot. The frong of the foot won't permit you to stitch nearer the cord than an eighth of an inch which is simply useless.

I heard one woman say who had been sewing for years, "there isn't any way of

A COMPLETE COURSE IN DRESSMAKING

machine stitching cording. It has to be stitched by hand." Probably all the time, there was a cording foot packed away in her sewing machine drawer.

The cording foot is just like a regular foot except that the narrow frong isn't there. This makes it possible to stitch close to the cording. See Fig. 38.

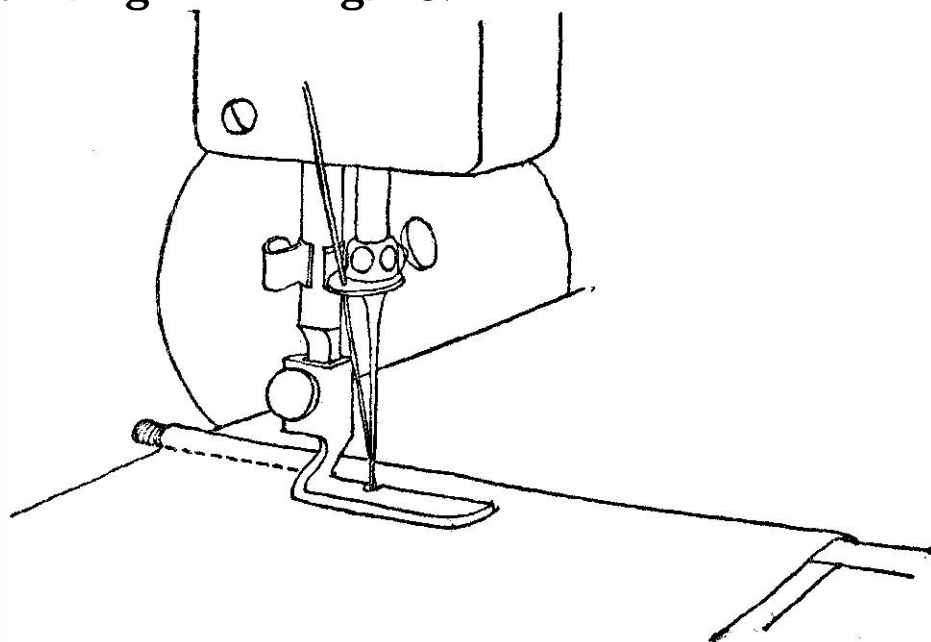

Fig. (38) A cording foot is made without the narrow frong that an ordinary sewing machine foot has.

You will find cording fully described in Lesson XII.

Probably in the seasons when cording is the style, every dress that you make will require endless cording. There is always more or less cording used to trim children's dresses.

Quilter or Foot with Gage.—Just because this sewing machine foot is called a quilter

PRELIMINARY INFORMATION

doesn't mean that it is used only for quilting. As a matter of fact, the name is rather misleading for the foot with a gage comes in handy for many ordinary purposes.

The novice at sewing especially cannot afford to be without the foot with a gage.

If you want to double stitch a seam, it will keep the second stitching even.

If you want to stitch back from the edges of a coat, it will keep the stitching exactly true.

If you want to add several rows of parallel stitching for trimming around a collar, use the foot with a gage to keep it parallel.

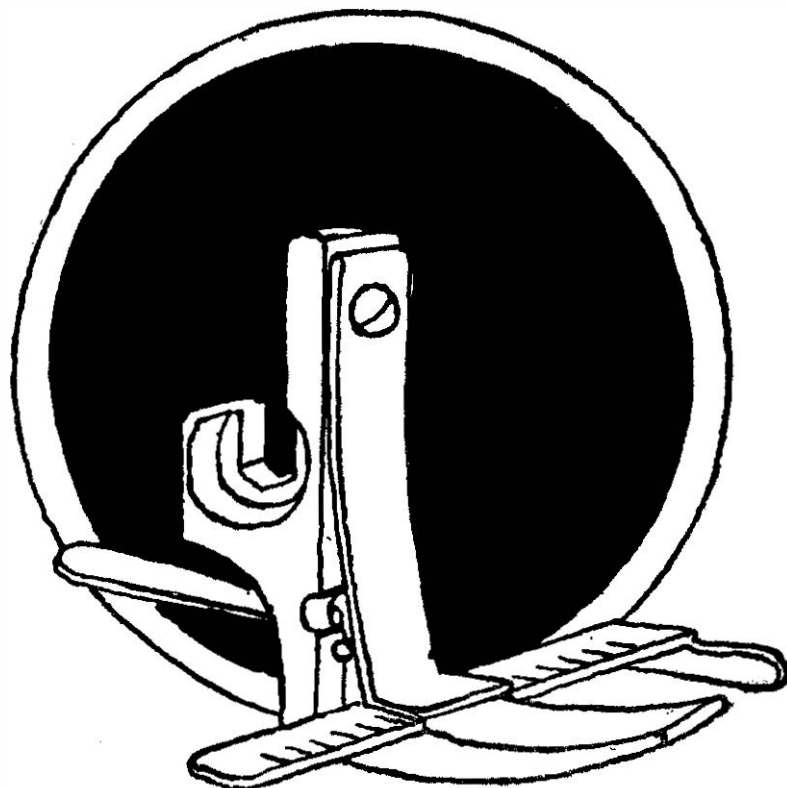

Fig. (39) A foot with a gage will help you to keep your stitching true.

A COMPLETE COURSE IN DRESSMAKING

It can be used for diamond shaped quilting, too. It will keep the rows exactly even.

Fig. 39 shows the attachment. It goes onto the machine just like the regular sewing machine foot. Three minutes with your screw driver will attach it.

HAND SEWING

Do you vary the stitches you use in hand sewing? One kind of a stitch wont serve for all purposes you know. Suit the stitches to the kind of work that you are doing. Here are the stitches you will need to use the most. Practice making them until you are adept with your needle.

Running Stitch.—The simplest of all hand stitches is running stitch shown in Fig. 40. Making this stitch is merely a matter of running the needle in and out of the goods at regular intervals. It is the kind of a stitch that is used for handrun seams and gathering.

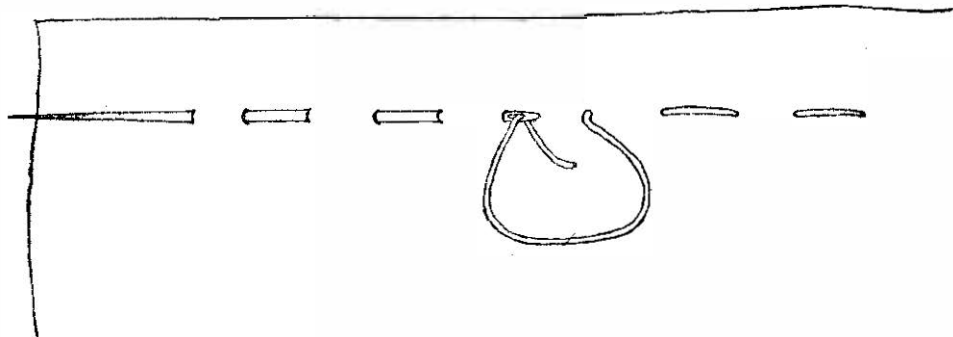

Fig (40) *Running stitch which is used for basting, handrun seams, etc.*

PRELIMINARY INFORMATION

Once you have inserted the needle in the goods do not remove it until the needle has all the material on it that it will hold.

Running stitches for ordinary purposes are made usually about one-eighth of an inch long. However, an old rule which always holds true is "The finer the material, the shorter the stitch."

Keep in mind two things in practicing to make running stitches. *Make them as evenly as possible and keep them in a straight line.* A crooked seam is an acknowledgment of the lack of practice.

It is a good idea for the beginner to mark the exact stitching line with a tracing wheel run along the edge of a ruler.

Back Stitch.—One might almost call this a stay stitch for that is its purpose. If you want hand sewing that is firm use back stitches. See Fig. 41.

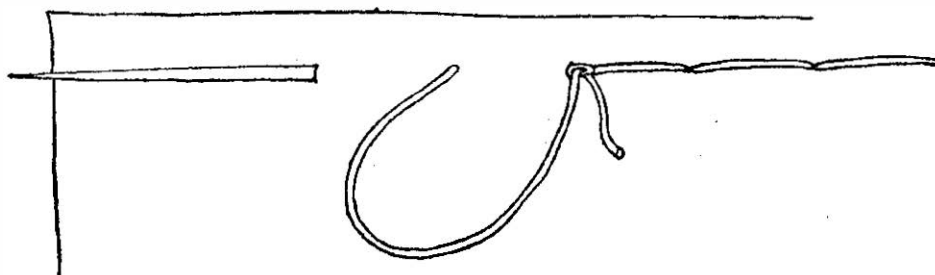

Fig. (41) Back stitches hold the goods firmly.

They are formed by inserting the needle as for a running stitch, bringing it out on the right side of the goods and inserting it a second time at the point where it was first

A COMPLETE COURSE IN DRESSMAKING

inserted. This time bring it out beyond the first stitch.

Sometimes, in a handrun seam, every fourth or fifth stitch is made a back stitch to strengthen the stitching. There are places where a seam finished in this way is to be preferred to a machine stitched seam. For instance, the daintiest and most expensive lingerie in the shops is made entirely by hand. A neatly run French seam, in a sheer camisole or chemise adds as much as the trimming. Babies' clothes too seem to call for a hand finish and certainly hand work adds to the little girl's sheer batiste or lawn frock.

Basting.—The basting stitch you use depends on what you are sewing. Seams are usually basted with a long and short running stitch. In this case, the long stitches are about one inch long and the short stitches measure about one-half inch.

In basting a seam, place the basting beyond the seam allowance. When you stitch, run the stitching just inside the basting. This makes it possible to remove the basting threads easily. However, if the stitching is directly on top of the basting, it is almost impossible to pull them out.

There is a cotton which comes especially for basting. It is easily broken. Ask for basting cotton.

PRELIMINARY INFORMATION

Always use a cotton that contrasts to the material. A matching cotton is difficult to see and pick out.

If you use sewing silk to baste silk material, the stitches will not be so apt to leave a mark.

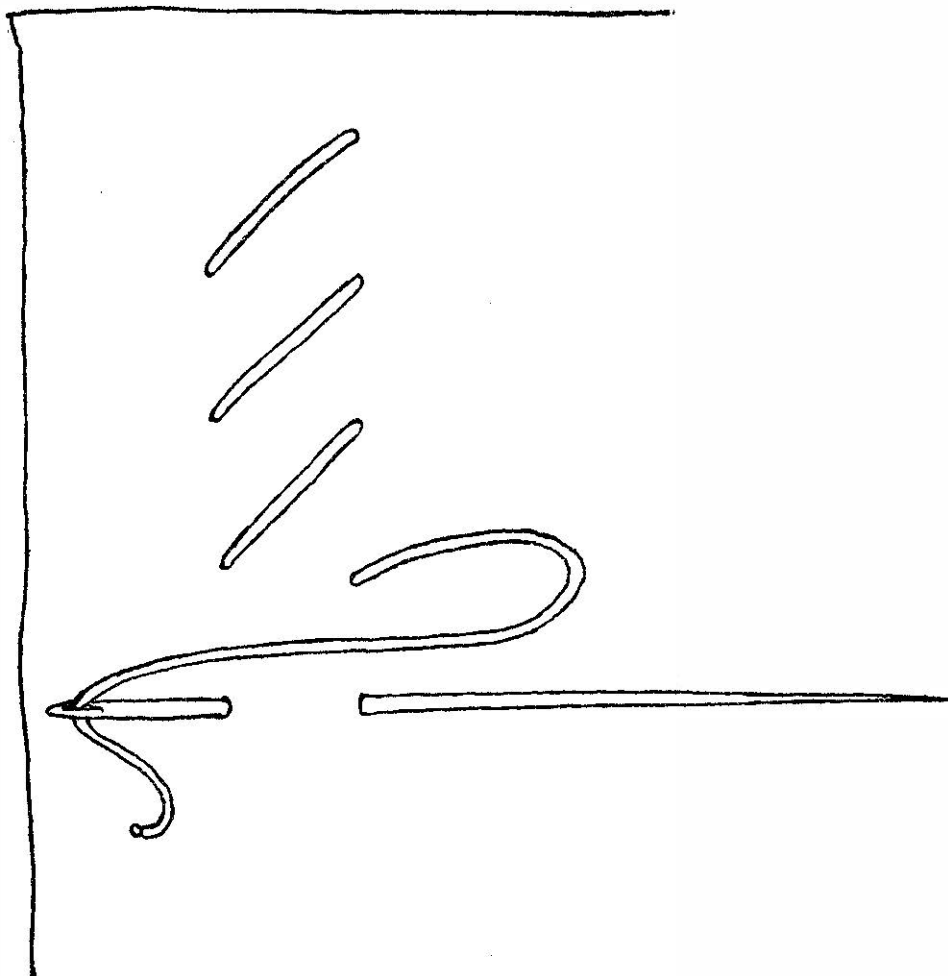

Fig. (42) Diagonal bastings are used to hold linings in place.

In basting one piece of material to another as a lining to a coat, use diagonal basting as shown in Fig. 42. Diagonal stitches hold more firmly than running stitches. In

[91]

A COMPLETE COURSE IN DRESSMAKING

diagonal basting, the cross stitches are about one-half inch wide and the diagonal stitches are about one inch long.

Overcasting.—Where you want to finish the raw edges of a seam, whip them with over and over stitches. See Fig. 43. It will prevent them from ravelling. If the stitches are placed about one-quarter of an inch apart the overcasting can be done rapidly.

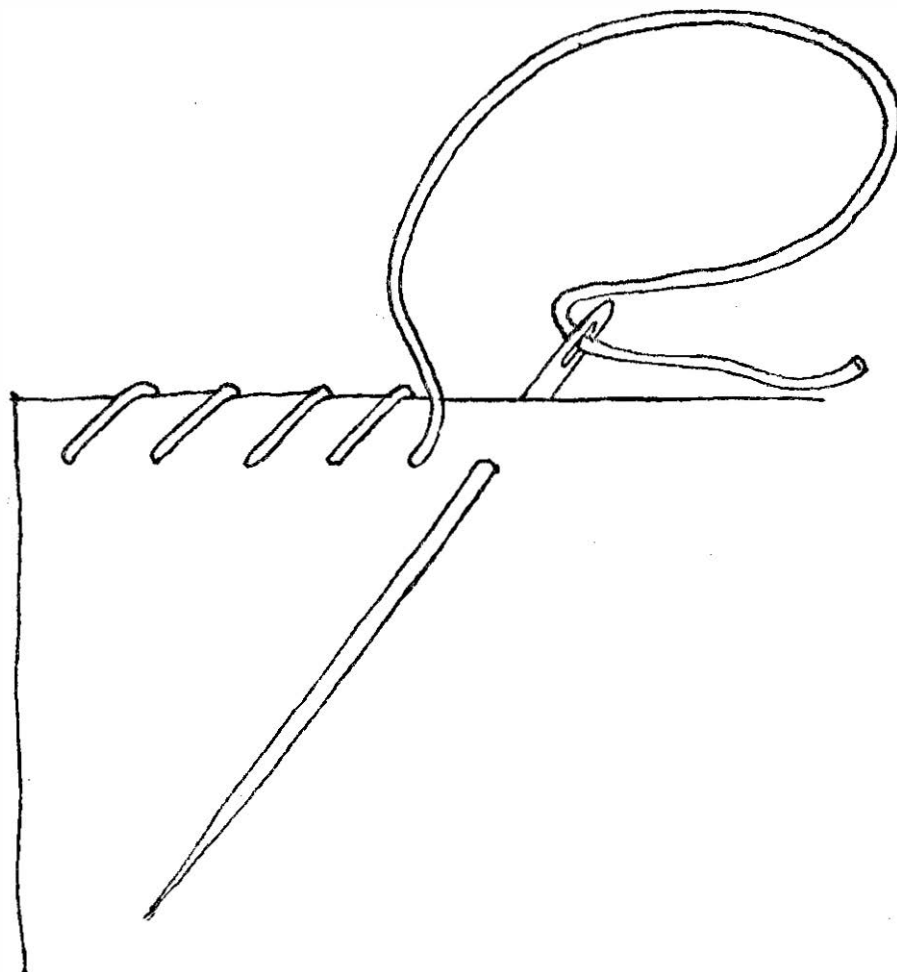

Fig. (43) Seams that are overcast will not ravel.

PRELIMINARY INFORMATION

It is a help to thumb tack the material to the sewing table, overcast for a ways, then thumb tack again further on.

Just overcasting makes a pretty trimming, too, for a child's dress. Sometime, try overcasting the collar and cuffs of a yellow chambray with black mercerized embroidery cotton.

Felling.—Hems, folds and lining are felled in place. This means taking stitches in the hem and outside material which will hardly show.

Insert the needle first in the hem, the fold or the lining and then in the outside garment as shown in Fig. 44. Take up only a thread or two of the outside goods as the

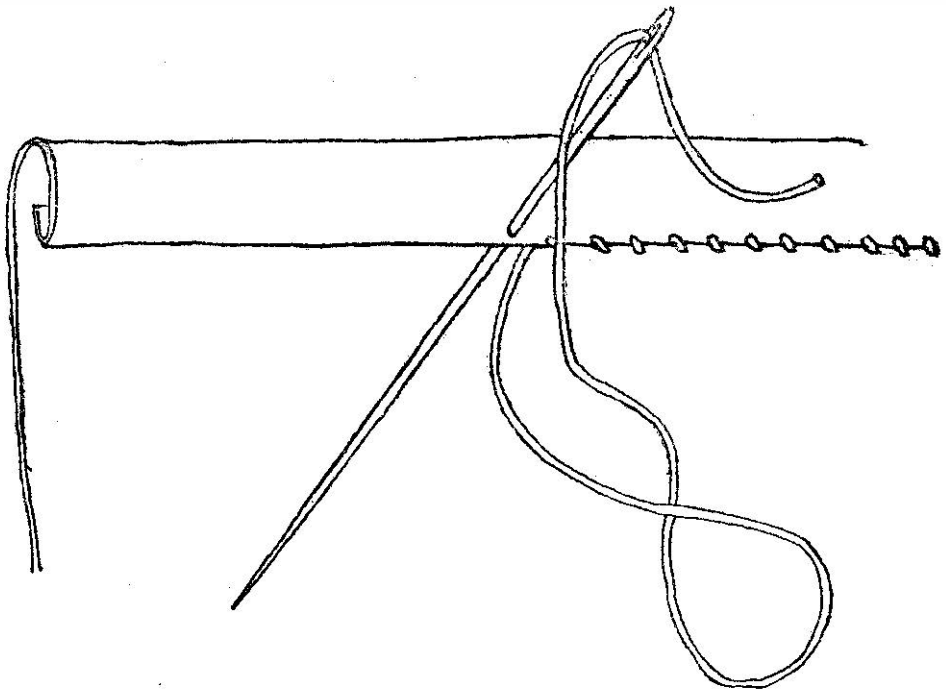

Fig. (44) The correct position of the needle in felling a hem.

A COMPLETE COURSE IN DRESSMAKING

stitches ought not to show on the right side of the goods.

In turning a hem, you will find it a great help to press it before attempting to fell it in place. Folds ought to be thoroughly pressed before they are sewn to the garment.

Blind Stitching.—It is possible to blind stitch more quickly than to fell by hand because in blind stitching the stitches are placed further apart.

Blind stitching is used to tack trimming in place. For instance, the girdle that looks loose and careless yet ought to be firm. Just a blind stitch here and there will hold it.

Fig. 45 shows the position of the needle. The stitches may be placed from one-half inch to five inches apart, as the case requires.

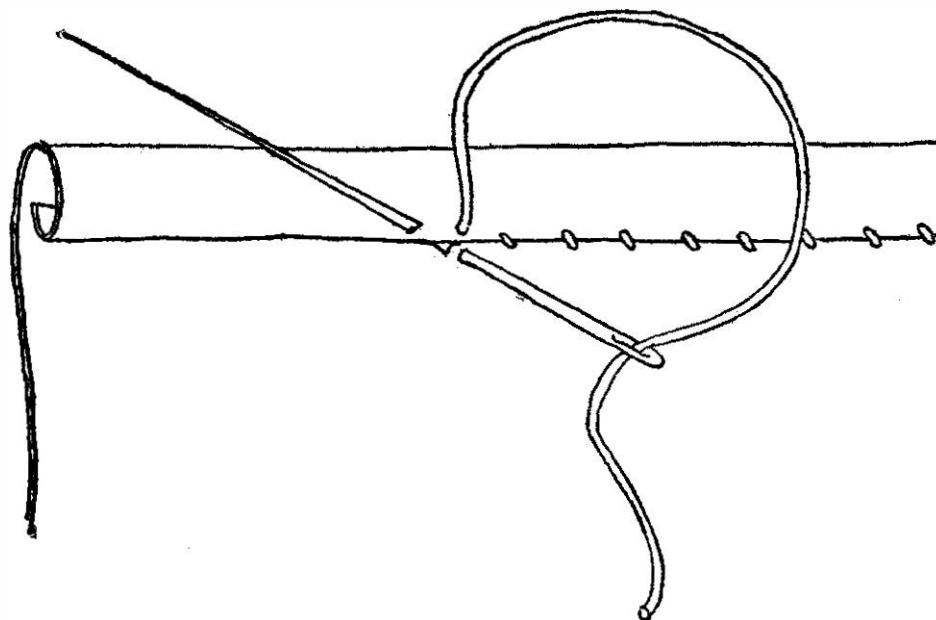

Fig. (45) An enlarged view of the so-called blind stitch

PRELIMINARY INFORMATION

SEAMS AND THEIR USES

Suit your seam to the material and the place. Thick materials need as flat a seam as possible. On the other hand, in thin goods it is often advantageous to give quite a different finish.

We have all heard the remark that a certain garment has a homemade look. It may be, too, that the garment is carefully and neatly made. It is not always the case, but very often the fault can be traced to seams. There is a thick seam where there ought to be a thin one and a tailored finish where there ought to be a delicately hand-run seam. And so it goes. The garment isn't well turned out.

Study your material and use the right seam.

Open Seams.—Where a flat finish is desired, press the edges of a plain seam open. See Fig. 46.

For instance, you would know at a glance that a heavy overcoating ought not to be stitched into a French seam. Four thicknesses of the goods would make a bulky unsightly ridge. However, if the two pieces of the overcoating are placed with the right sides of the goods together and stitched the length of the seam and the seam pressed open, the joining will hardly show.

A COMPLETE COURSE IN DRESSMAKING

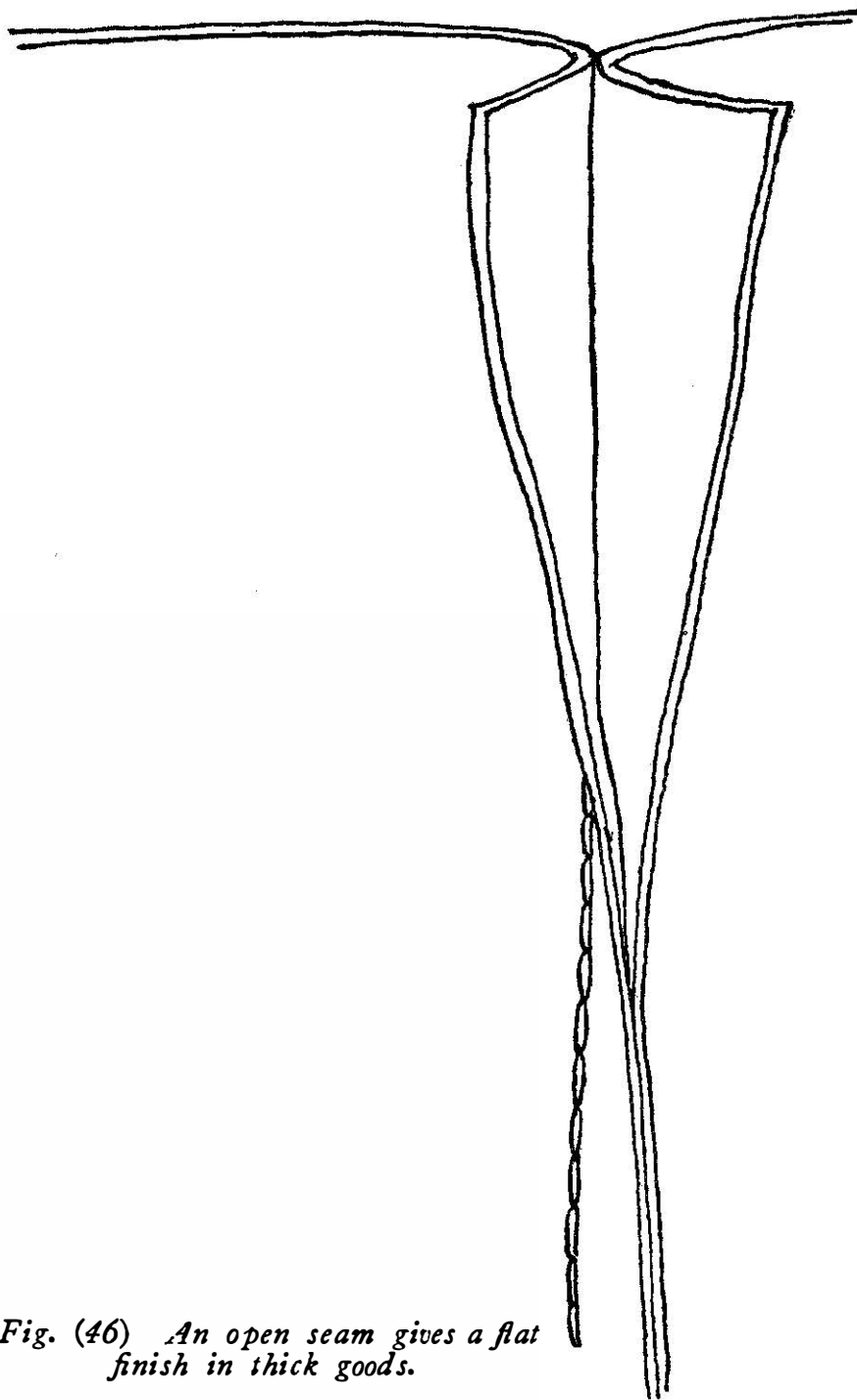

Fig. (46) An open seam gives a flat finish in thick goods.

The seams of a woolen skirt are often pressed open, too, and where a dress material is heavy, it is best to press open the seams.

PRELIMINARY INFORMATION

The edges of an open seam are finished with a binding or overcast. See Lesson II, for binding.

French Seams.—Probably the French seam is used more than any other in ordinary

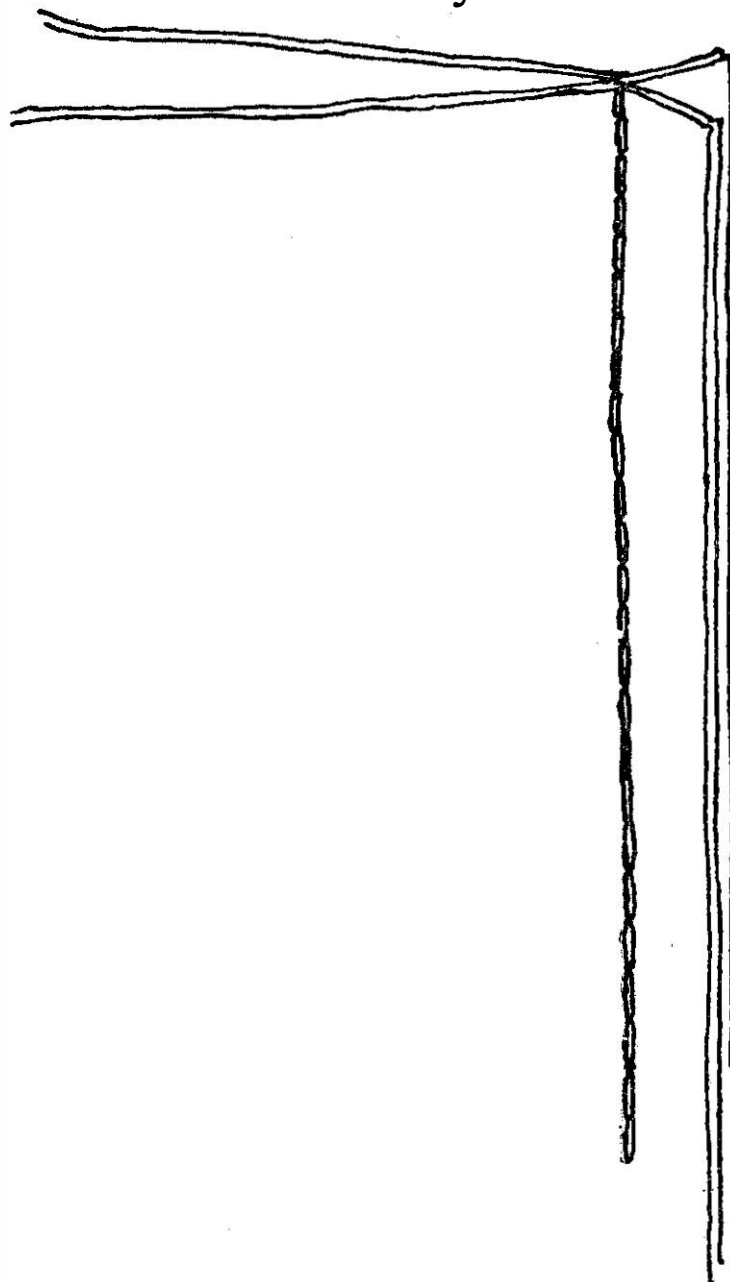

Fig. (47) An enlarged view of the first stitching in a French seam.

A COMPLETE COURSE IN DRESSMAKING

sewing. A French seam is the neatest finish for underwear, cotton dresses, blouses and little girls' frocks of gingham, chambray, organdie and like materials.

A French seam is also used for silk and no finish is daintier than a French seam hand run in a batiste chemise, an infant's nainsook frock or a little girl's party frock of chiffon.

To make a French seam, lay the two pieces to be joined with the wrong sides of the goods together and stitch the length of the seam, running the stitching one-eighth of an inch from the edge. See Fig. 47. Turn the pieces wrong side out and crease along the joining. Press the garment and stitch a second time, running the stitching one-quarter of an inch from the creased edge. See Fig. 48.

This gives a neat finish on both the right and the wrong side of the garment but a French seam won't answer for every purpose.

Don't use a French seam in thick material. It is too bulky.

Don't use a French seam where you want a flat finish. For instance, at the shoulder a French seam will make a ridge. Except in sheer materials, an open or double stitched seam is better.

Don't use a French seam where you want a tailored finish. A tailored blouse or a boy's shirt looks better with double stitched or lap felled seams.

PRELIMINARY INFORMATION

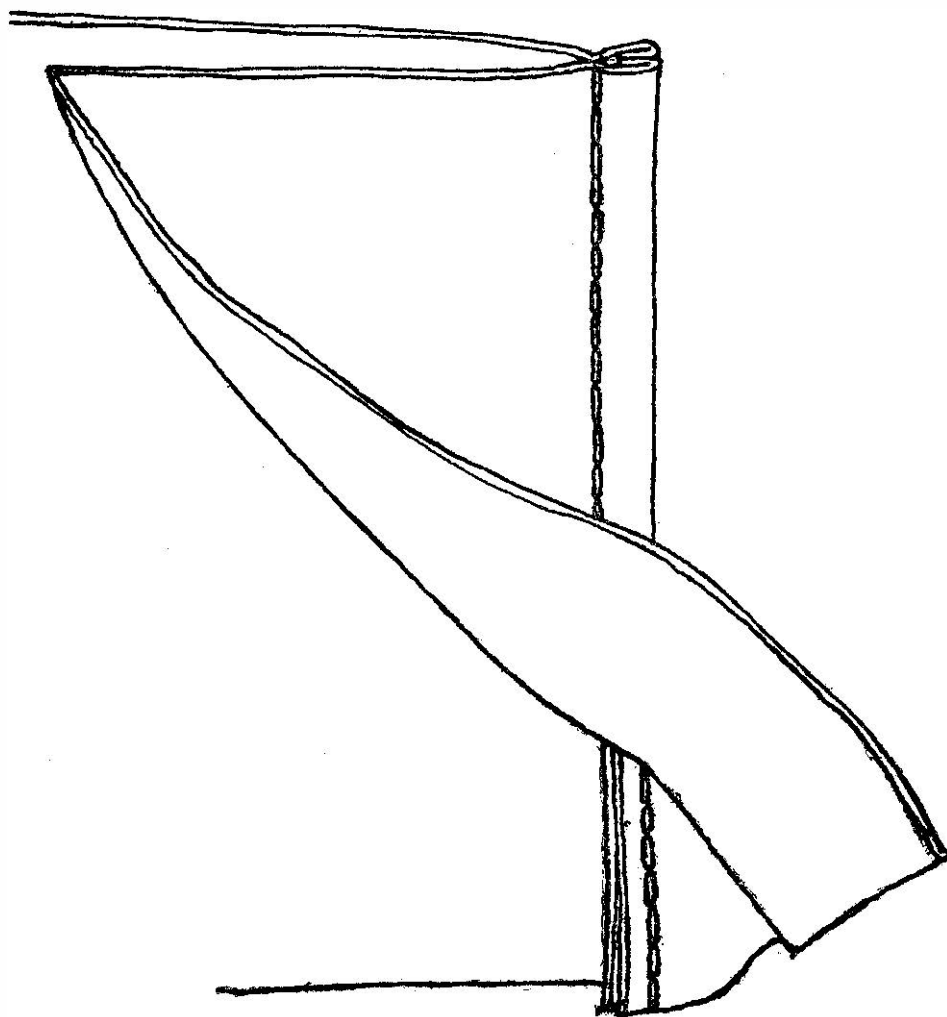

Fig. (48) The second stitching in making a French seam.

Double Stitched Seams.—If the raw edges of a plain seam are both turned in one direction and the seam stitched a second time, it is called a double stitched seam. See Fig. 49. Such a seam will give a garment a tailored appearance.

Double stitched seams are used in some cases at the side front and side back seams of a coat.

A COMPLETE COURSE IN DRESSMAKING

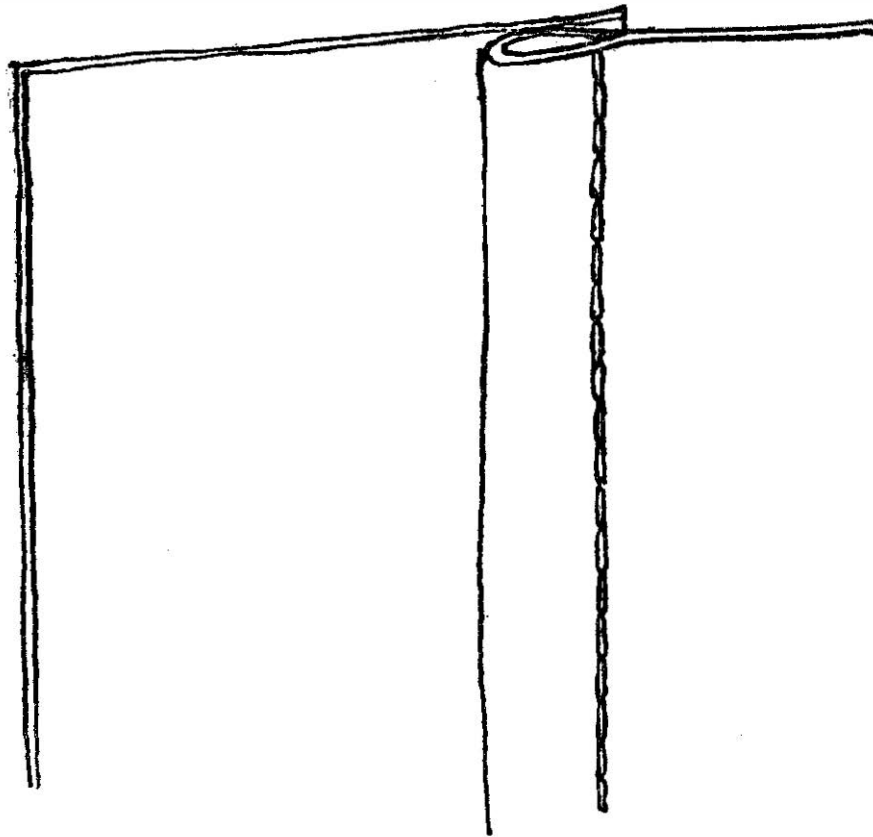

Fig. (49) Double stitched seams are used where a tailored finish is desired.

If a dress is semi-fitted with a dart or side front seams, the dart or seam is usually double stitched. Sometimes where speed is to be considered, it is also used in the place of lap felled seams in blouses and children's clothing.

To make a double stitched seam, lay the two pieces to be joined with the right sides of the material together and stitch the length of the seam, running the stitching a seam's width back from the raw edges. The regulation seam allowance is usually three-eighths of an inch. Open up the garment and turn

PRELIMINARY INFORMATION

both raw edges of the seam in one direction. Press the garment and stitch again. This time stitch from the right side of the garment and run the stitching parallel to the seam.

Here is where a sewing machine foot with a gage comes in handy. The gage can be set the distance you want the stitching from the seam. Then, in running through the material, place the edge of the gage on the joining of the seam and the needle will stitch evenly the exact distance back from the seam that you want the second stitching.

The distance the stitching is placed back from the seam is a matter of choice. In a coat or dress the stitching varies from one-eighth of an inch to one-quarter of an inch from the seam.

Lap Felled Seams.—You will recall that I have already told you how to make a lap felled seam with the special attachment—a narrow hemmer—in place of the regular sewing machine foot.

It is also possible to make a lap felled seam with regular sewing machine foot, although it means turning the edge by hand. For the first stitching, lay the two pieces to be joined with the right sides of the goods together, letting the under piece extend one-quarter of an inch beyond the edge of the upper piece. Stitch the length of the seam, running the stitching one-quarter of an inch from the edge of the upper piece. See Fig. 50. Open

A COMPLETE COURSE IN DRESSMAKING

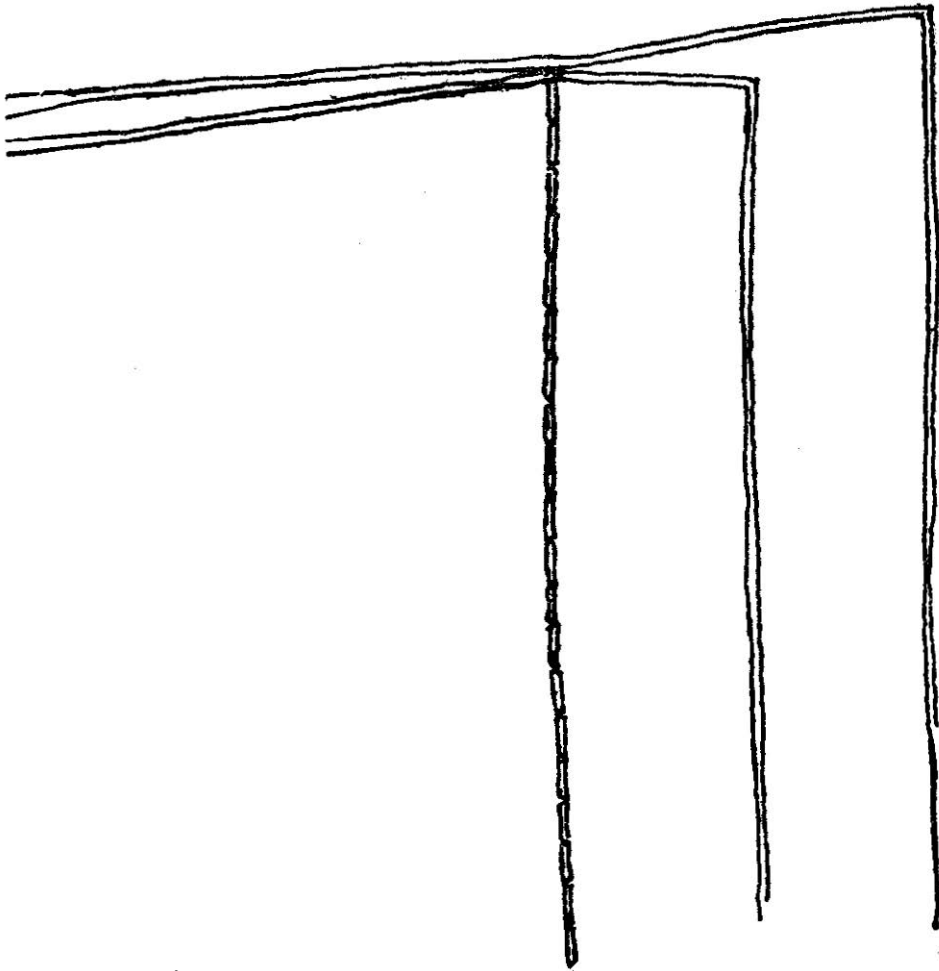

Fig. (50) The first stitching in making a lap felled seam.

out the garment and press the seam. Turn both raw edges of the seam in one direction and press the seam. Turn under the raw edge and stitch a second time as shown in Fig. 51.

This gives you a flat seam finished on both sides. Perhaps you are wondering why it is called a lap felled seam when it is stitched by machine. The seam was named at the time when all sewing was done by hand. Then, the first joining was done with running

PRELIMINARY INFORMATION

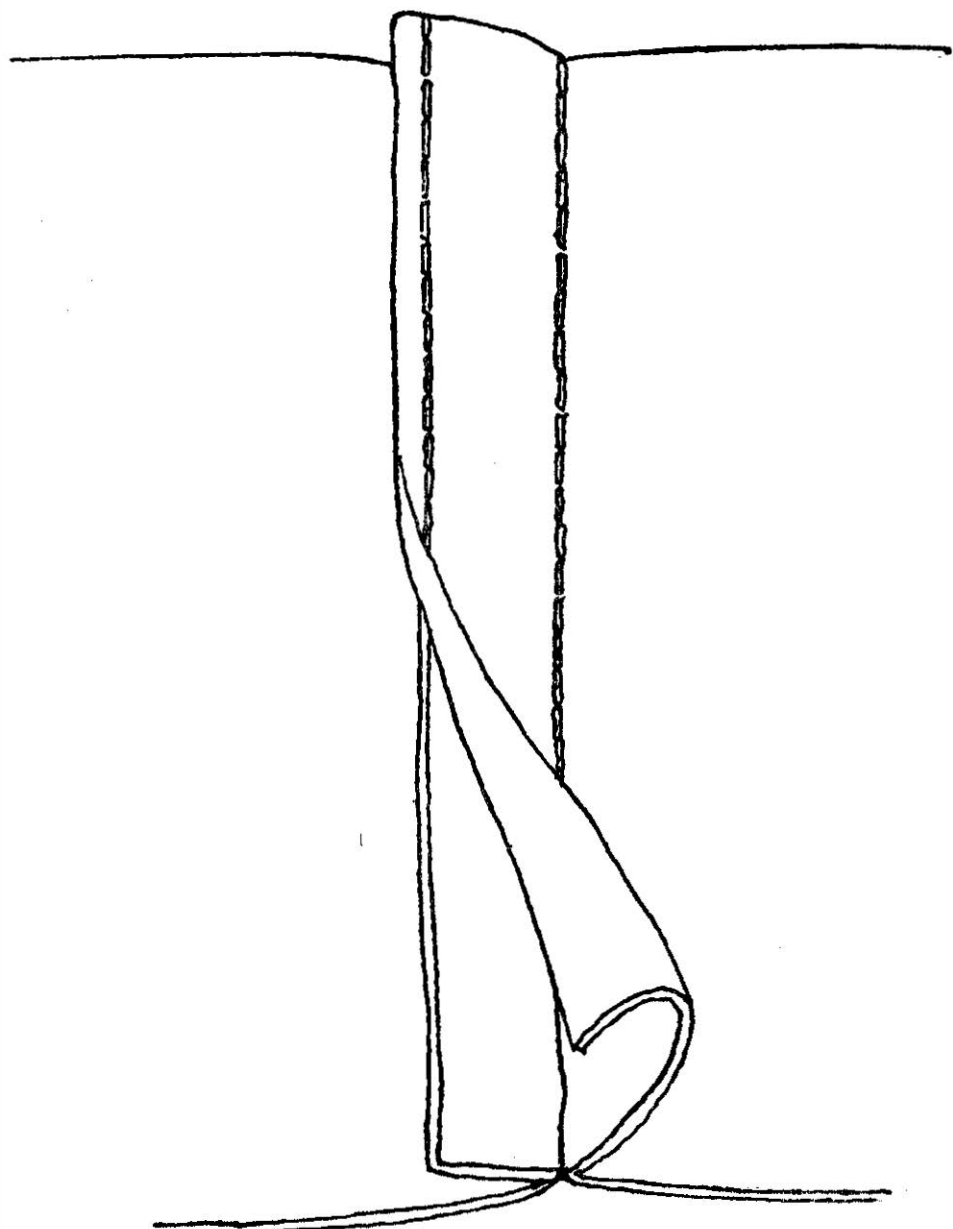

Fig. (51) A lap felled seam completed.

stitch and the raw edge caught down on the wrong side of the garment by hand felling and so we have the name lap felled seam. Even today, where it is best not to have the second stitching show, the raw edge is caught by hand felling.

A COMPLETE COURSE IN DRESSMAKING

A lap felled seam always gives a tailored look to the garment. It is used in making men's shirts, underwear and pajamas, also for boys shirts, wash trousers, underwear and pajamas. It gives a plain blouse style to tailor it with a lap felled seam. It is a good finish, too, at the shoulder of little girls' wash dresses.

A lap felled seam never looks nice in transparent material such as chiffon or very thin muslins.

A Slot Seam.—Where the edges of two pieces are turned under and they are joined to an inset section, tuck fashion, the joining is called a slot seam. It really adds a trimming. See Fig. 52.

The center front of a skirt is often finished with a slot seam. It's a pretty way, too, of trimming children's clothes, especially if the under section is of contrasting material. A navy blue serge with the undersections of the slot seams bright red or green is effective. A little girl's dress may have slot seams at the center-front, the center-back and the sides of the skirt; also at the center-front of the waist.

To make a slot seam, bind either edge of the under facing. See binding, Lesson II. Turn under the edges of the two pieces to be joined and lap them over the under facing, letting the edges of the two pieces just

PRELIMINARY INFORMATION

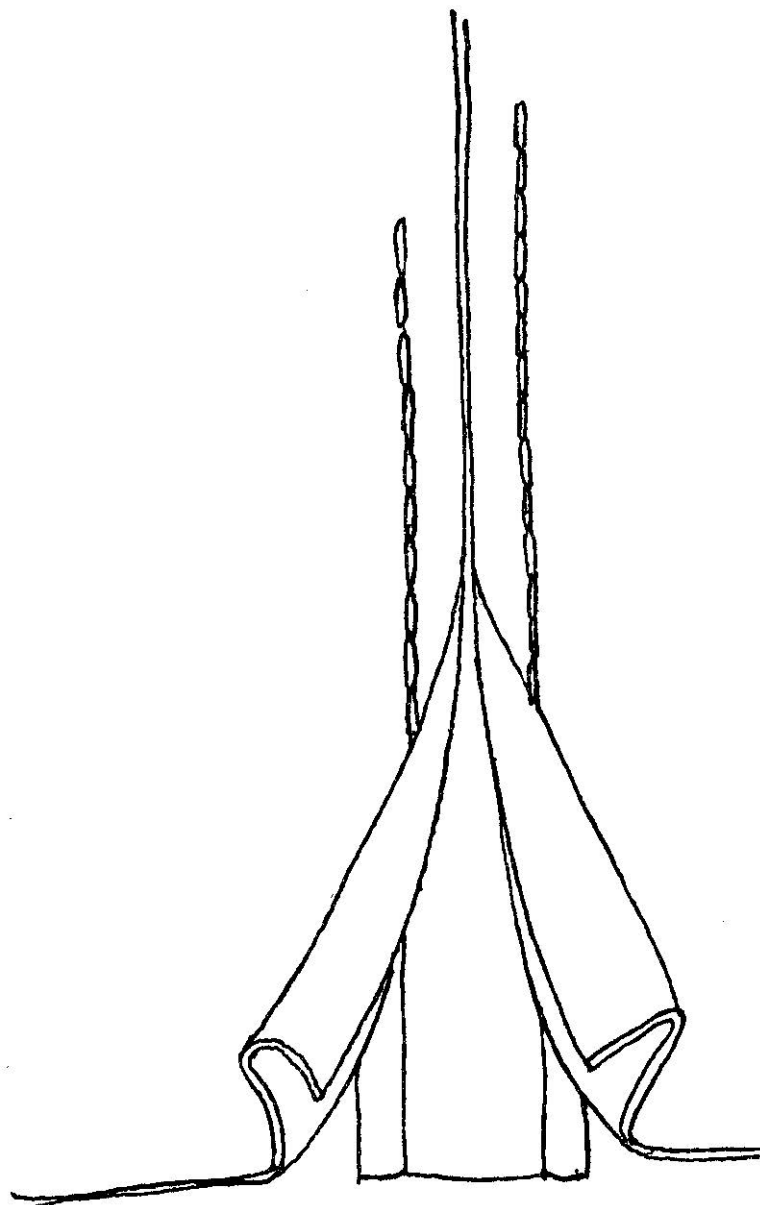

Fig. (52) A slot seam makes a pretty trimming for children's dresses.

touch at the center. Stitch any desired distance back from the edges. See Fig. 52.

Sometimes, the two pieces are spread apart a little letting the inset section show more. The amount you spread them is a

A COMPLETE COURSE IN DRESSMAKING

matter of taste. They are spread all the way from one-quarter of an inch to an inch.

HOW TO TAKE MEASUREMENTS

The following measurements are necessary and after they are obtained, should be kept ready for reference all the way through in the making of a garment:

Bust measure

Neck measure

Width of chest

Width of back

Length of front from neck to waistline

Length of back from neck to waistline

Length of sleeve

Waist measure

Hip measure

Length from waistline to floor at center front, center back and each side

Remove the Dress to Take all Measurements.—Measure over the underwaist and petticoat. In ordering commercial patterns, always order by the actual measurement. Allowances are made in the patterns for different types of garments. For instance, a pattern for a coat is made larger than a pattern for a blouse, although they are both marked the standard size as thirty-six or forty.

Taking the Bust Measure.—Stand behind the person being measured and pass the tape

PRELIMINARY INFORMATION

around the form loosely. Hold it between the thumb and first finger of the right hand at the center back and with the left hand slip it down in the front over the fullest part of the bust. Bring it well up under the arms and high across the back over the fullest part of the shoulder blades. Draw up the tape snugly but it ought not to be really tight. Note what the measurement is in inches.

The Neck Measure.—Also take this measurement from the back, passing the tape around the base of the neck. Draw it snugly.

The Width of Chest.—Measure across the chest at a point that would be about two-thirds of the way down the armholes of the finished garment. Do not continue the tape under the arm but take the measurement from arm muscle to arm muscle.

The Width of Back.—Measure across the back at a point about half way down the armhole. This gives you the narrowest point across the back and is the width that the garment ought to measure across the back.

Length of Arm.—The best way of determining the length of the arm, is to place the yard stick or a tailor's square under the arm and note the length to the wrist. If a square is used, place the short arm of the square across the armpit and let the long arm extend along the inside of the arm. The sleeve

A COMPLETE COURSE IN DRESSMAKING

length ought to be taken to the joint at the wrist.

The Waist Measure.—In taking the waist measure, you will find it a help to place a cord around the waistline to locate the smallest point. Make a loop in one end of the cord and place the cord around the waistline, pass the other end through the loop, draw up the cord tightly and tie it. It will naturally slip to the smallest part which is the normal waistline. Measure over the cord with the tape. Even if you want a loose garment or one with fullness, this measurement will give you the right basis on which to work.

The Hip Measure.—Before removing the cord from the waistline, measure down at the center front, center back and sides six inches and fasten pins to the skirts at these points. Measure around the skirt over top of the pins for the hip measurement. (Note.—The six inch point is where the hip measure is usually taken, however, some commercial patterns specify that the hip measure is taken at a lower point.)

Length of Front from Neck to Waistline.—You will find it a great help to know the length from the neck to the waistline. Take this measurement while the cord is around the waistline.

Length of Back from Neck to Waistline.—Measure from the neck bone at the base of

PRELIMINARY INFORMATION

the neck in the back to the cord at the waistline.

Length from Waistline to Floor.—It's a poor plan to attempt to measure the length of the skirt that a woman is wearing. Measure from the waistline to the floor—it will give you a better guide to work with. Then if you want the skirt, six, eight or ten inches from the floor you can subtract it from the total amount. Have the person being measured stand squarely with her heels together and measure from the cord at the waistline to the floor at the center front, center back and sides.

SEWING EQUIPMENT

Of course you have your sewing machine. It's hard to find a woman who hasn't these days. Well, all you need to start right in sewing is a needle and thimble, a pair of shears and a tape measure.

As a matter of fact, it's a good plan not to buy a whole lot of equipment until you have sewed a while and found out just how much you really need and just how much you can do without.

However, perhaps later on you will make a profession of Dressmaking and here is a little list *for an ideally equipped sewing room* that you can use for reference at any time:

Chest of drawers

Closet or wardrobe

A COMPLETE COURSE IN DRESSMAKING

Cutting table
One or two full-length mirrors
Ironing board (regular size)
Sleeve board
Iron
Basin
Sponge
Press cloth of duck or canvas
Shrink cloth
Several strips of muslin with which to
cover work
Wire coat and dress hangers
Dressmaker's dummy
Square
Yard stick
Curved ruler
Steel tape
Steel tracing wheel with sharp points
Heavy shears for cutting cloth
Shears for cutting paper
Small scissors for clipping threads
Waste paper basket for clippings
Paper weights
Pins
Needles
Thimble
Elastic bands
Tailor's wax and chalk

PRELIMINARY INFORMATION

Pad of paper and pencil

Sharp knife

The chest of drawers is needed for patterns, material and sewing equipment. It is a good plan to keep one drawer for patterns, one drawer for new materials, one drawer for garments which are cut out, another for tools, and one for left-over ends and scraps of material.

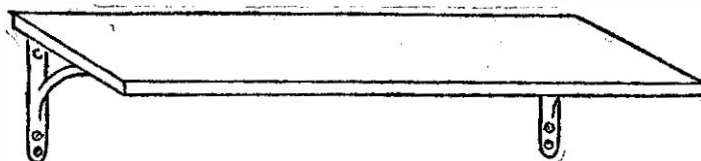

Fig. (53) *A shelf will serve in place of a closet.*

From the very start, make it a habit to mark for whom each pattern is, and always take time to fold the pattern into its proper envelope before putting it away.

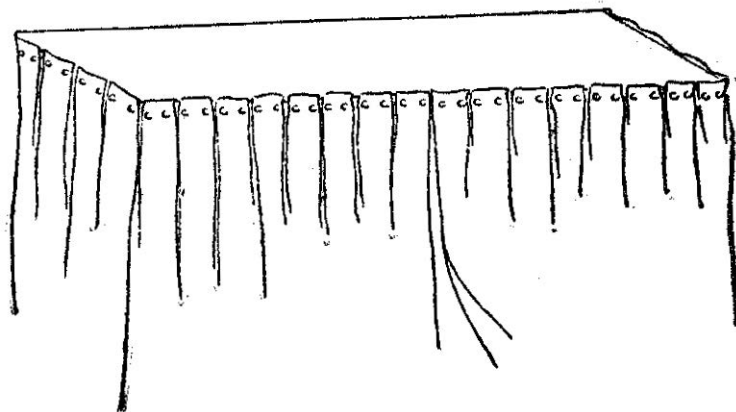

Fig. (54) *The curtains adjusted to shelf.*

When garments are partly or nearly finished, hang them up when you stop sewing. It prevents them from getting soiled and mused. If your sewing room has a closet, it easily

A COMPLETE COURSE IN DRESSMAKING

solves the problem of where to hang them. If there is no closet and you do not want to go to the expense of buying a wardrobe, *a shelf put up on brackets with a curtain tacked to it will answer the purpose of a closet.*

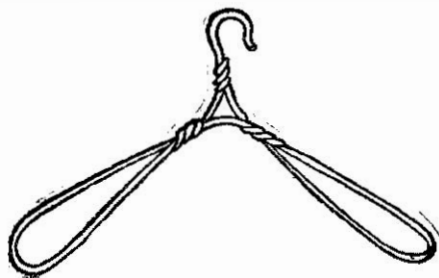

Fig. (55) Hang up the coat or partly finished dress to prevent it from wrinkling.

The Figs. 53 and 54 show the shelf and curtain. Suitable wire coat and skirt hangers can be bought at any department or five and ten cent store. Good types are illustrated in Figs. 55 and 56.

The cutting table ought to be forty inches or wider and at least two yards long. If your space is limited have a carpenter build horses and a collapsible top. (See Figs. 57, 58 and 59.) A table of this description can be easily taken apart and leaned against the wall.

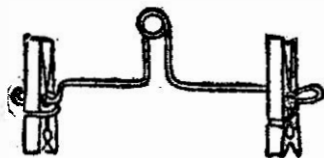

Fig. (56) Trousler hangers answer admirably for hanging up a skirt.

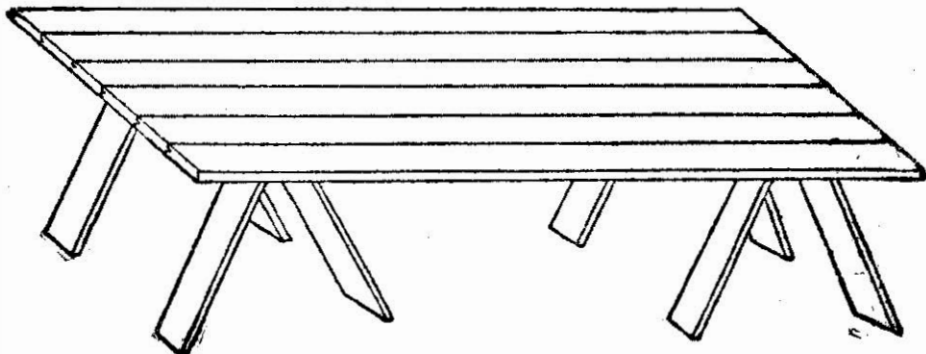

Fig. (57) A wide cutting table is a great advantage.

PRELIMINARY INFORMATION

If the top of the table is soft wood and smooth it is not necessary to cover it. However, in time it is bound to rough up from the tracing wheel. It pays to cover any table with linoleum or heavy oilcloth. If linoleum is used shellac it so the fabric will not cling to the surface.

If you have *two mirrors* place them opposite each other so that by looking in one glass you can see your back in the other.

An ironing board without a frame is the most satisfactory. A skirt can be slipped over it without danger of crushing the part that comes at the under side of the board.

If your table is supported by horses, these will work nicely for the ironing board too, or rest the board on the backs of two chairs.

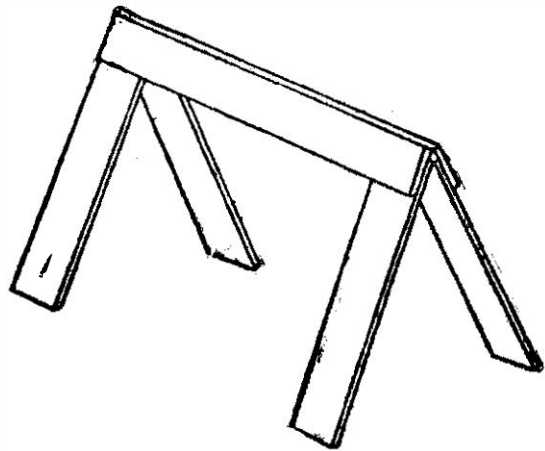

Fig. (58) *The horse for a collapsible table is easy to make.*

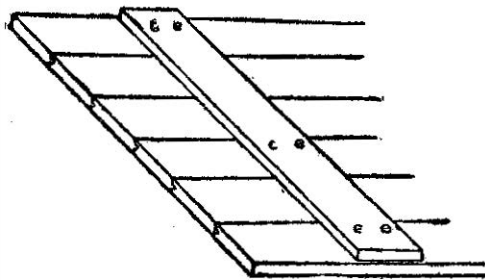

Fig. (59) *The top of a collapsible table.*

Be sure to pad your board well. Tailors' wadding can be used for this purpose, put on in smooth, even sheets. Fold the wadding over the edge and tack it to the under

A COMPLETE COURSE IN DRESSMAKING

side of the board. Several thicknesses of a woolen bed blanket also make a satisfactory padding. After the padding is tacked to the board, cover the board with several thicknesses of muslin. Draw the outside muslin tightly and smoothly, rolling it over edge and sewing it securely or tacking it to the under side of the board.

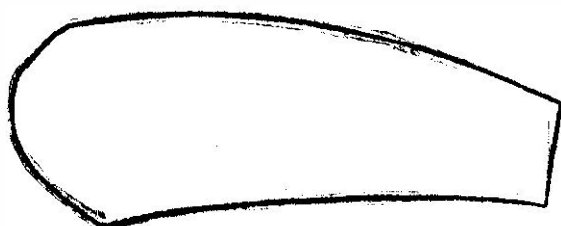

Fig. (60) *A sleeve board is an advantage in pressing a coat sleeve.*

For coat making, you will need *a sleeve board*. (See Fig. 60.) This, too, needs a thick padding.

An electric iron is a great convenience but not a necessity. A one burner gas stove or a small oil stove and an ordinary flat iron make a practical substitute.

Do not try to get along without an iron and ironing board.

Pressing is One of the Most Essential Things in Garment Making.—It is impossible to do neat work unless each piece is pressed before joining and every edge pressed before stitching.

Include in your pressing outfit *a press cloth, a basin for water, and a small sponge.*

Duck makes the best press cloth as it does not cling to the iron. The press cloth ought to be about a yard and a quarter long.

PRELIMINARY INFORMATION

Most cotton wash fabrics can be pressed successfully without a press cloth, but *cottons in woolen finish and woolens must be covered with a damp cloth* or the heat of the iron will shine the surface.

Press silks from the wrong side and with an iron only lukewarm. Heat rots silk.

Seams are pressed open more easily if they are dampened; so keep a basin of water and a sponge handy.

Cottons and woolens ought to be well shrunk before they are made up. Wash goods is easily shrunk by soaking in water and hanging in a shady place to dry. *It is the slow drying that shrinks it.*

Woolens or cottons in woolen finish are treated differently. The best home method is to wrap the fabric in a wet cloth. Duck makes a good shrink cloth. The shrink cloth ought to be about a yard longer than the material.

Lay the fabric on a flat surface, smooth out the wrinkles, dip the shrink cloth in water and cover the fabric with it. Roll shrink cloth and fabric over a board. The thin boards on which bolts of fabric are wrapped are excellent for this purpose.

The fabric must be wrapped in the wet cloth at least twenty-four hours. It is then unrolled, hung up to dry and pressed while it is still damp. *Mere sponging with a damp*

A COMPLETE COURSE IN DRESSMAKING

cloth or sponge will not shrink material sufficiently so that it can be properly handled in tailoring. Material that has not been properly shrunk is sure to shrink and pucker under the iron when pressing.

You will find several strips of muslin about three yards long a great help in keeping your work clean. For instance, if you stop working when a garment is half cut you can cover your cutting table with one of these pieces of muslin. The same thing applies to the machine. You need not always take the work out of the machine, but can throw the muslin over the machine to keep the work clean.

There are many good adjustable *dress forms* on the market, but you can make an ordinary form answer your purpose. If you are sewing just for yourself, buy a size as near your measurement as possible.

Make a muslin French lining that fits you and slip it over the form. If it is too loose at any point, pad it out.

If you are making a business of dressmaking, buy a medium size form and pad out muslin linings for larger sizes, making them detachable so you can slip them on and off the form.

The Fig. 61 gives an idea of the type of *curved ruler* to buy.

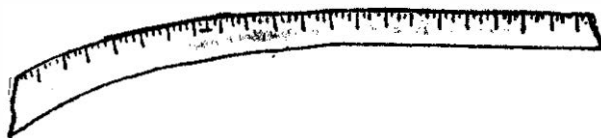

Fig. (61) *A curved rule will help you with your pattern making.*

PRELIMINARY INFORMATION

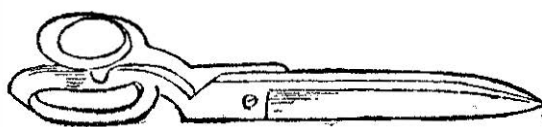

Fig. (62) *The cutting shears must be heavy.*

Heavy shears are needed for cutting fabrics, as illustrated in Fig. 62. These ought to be kept very sharp and used only for cutting fabric. Keep a second pair of shears for cutting paper, and a small pair of scissors for clipping threads.

Many of the cloth tape measures are not accurately marked. Compare your cloth tape measure with the yard stick. A steel tape such as the one shown in Fig. 63 is always right.

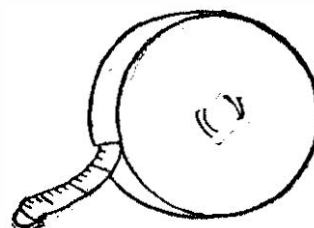

Fig. (63) *A steel tape measure is always accurate.*

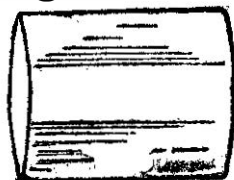

Fig. (64) *Chalk and wax for marking around the pattern come in convenient little cakes.*

Keep tailor's wax and chalk for marking around the pattern on the goods. Use the wax only on the outer edges where the marks will be cut off. Chalk marks can be whisked off of woolens. The chalk and wax come in little cakes, as Fig. 64, and are packed in boxes. They come in white; also gray, black and red, and are on sale at all dressmaking and tailors' supply stores.

A steel tracing wheel is a good investment. It can be used for copying patterns or marking tucks or pleats on fine silk without injuring the fabric. A tracing wheel with rough or blunt points will tear and cut silk.

A COMPLETE COURSE IN DRESSMAKING

Keep a good supply of *pins and needles* on hand. It is a waste of time to stop in the middle of your work and go to the store for the necessities.

Black headed steel pins are the best to use. They are much easier to pick up than the ordinary metal pin and they are so slender and sharp that they will not mar even fine fabrics.

Elastic bands come in handy for slipping on a bundle of cut-out pieces or the pattern if the envelope is torn.

Paper weights are excellent for holding the pattern to the goods while cutting. No sewing room is complete without paper, pencils and a sharp knife.

If You Have no Sewing Room, keep a chiffonier or chest of drawers in which to put your work. Also reserve one closet or part of a closet in which to hang the partly finished garments.

Where the dining-room table must be used for a cutting table, buy the rubber floor matting such as is used in hospitals. It is thick enough so that a tracing wheel will not punch through. It can be rolled up when not in use.

Another way of protecting the table is to quilt a thick pad, put this on the table and then cover it with table oilcloth.

PRELIMINARY INFORMATION

If you sew in your living room or bedroom, spread out a piece of table oilcloth and place the sewing machine on this. After you are through sewing it is an easy matter to push the machine off the oilcloth, gather up the oilcloth and slide the threads and bits into the waste paper basket.

HOW TO STUDY

Read Lesson I through three or four times. Study just one of the subjects at a time.

After you have read one subject through several times, run over it in your mind and see if there are any points on which you are in doubt. Read it through again, keeping in mind the points on which you want information.

After you are through studying Lesson I, give yourself a little examination. You know you would have to write out an examination paper if you were studying in a class. There are a list of test questions below.

Write down your answers and compare them with the information in Lesson I

TEST QUESTIONS

What styles are most becoming to a stout young girl?

What styles ought a short woman to avoid?

A COMPLETE COURSE IN DRESSMAKING

What colors are most becoming to a blonde?

Does a woman with a sallow complexion look well in black?

Does a stout woman look well in white?

What are the complementary colors?
Give list.

Can you give the definition of a complementary color?

Can you state the five rules for combining colors?

Which tension of your sewing machine needs the most regulating—the bobbin or the needle tension?

Can lace be sewed on with a sewing machine attachment?

Can you make a lap felled seam with an attachment?

What kind of seam is used at the shoulder of a coat?

What seam looks best in sheer materials such as organdie?

What is the correct position for a person taking the bust measurement?

What measurement is taken from arm muscle to arm muscle?

How do you determine the length of arm at the wrist?

Why is a press cloth necessary in pressing woolens?

PRELIMINARY INFORMATION

Is sponging and shrinking woollens the same process? Does it answer the same purpose?

A great deal of the data in Lesson I is for reference. When you take up the making of dresses, Lesson X, you will want to refer to **SUITABLE STYLES** and perhaps **BECOMING COLORS**.

In deciding on the seams to use in making the garments in Lessons III, IV, V, VI, VII, VIII, IX and X, it will be an advantage to have Lesson I handy to refer to.

The information about taking measurements is for reference later on, too. You will see how to apply this material when you take up blouses, dresses, pattern making and draping.

Lesson II shows the first steps in applying quick and efficient methods to sewing. It takes up the making of aprons and housedresses just to demonstrate several points in sewing.

Even if you have sewed before, it will be well to study Lesson II. Remember that it is not just the aprons and housedresses illustrated that you are learning to make but you are learning the principles which they illustrate. You will find many of the suggestions for the aprons apply to blouses, children's garments and ladies' dresses.

To become efficient, study the whole course in the order in which the books are printed.

INDEX

	Lesson	Page
Clothes for the Business Women.....	I	12
Clothes that Suit the Place and Season.....	I	5
Coarse Materials or Rugs, Removing Grease from	XII	52
Coat, Boy's.....	XI	31
Coat Buttons, How to Sew on.....	XI	11
Coat Collars.....	XI	13, 15, 17 & 22
Coat Cuffs.....	XI	17
Coat Draping.....	XI	14
Coat, Facing the Front of a.....	XI	7
Coat, Girl's Top.....	XI	34
Coat, How to Make a Woman's.....	XI	1
Coat, If Finished without a Lining.....	XI	34
Coat, Making with Canvas Interlining.....	XI	5
Coat, Pattern Lengthening or Shortening.....	XI	3
Coat Sleeve, Finishing a.....	XI	9
Coat with Peplum.....	XI	12
Coat, Women's Norfolk.....	XI	17
Coat, Women's Top.....	XI	25
Cocoa or Chocolate Stains, Removing.....	XII	50
Coffee Stain, How to Remove.....	XII	50
Collar and Pocket Lining, Material for.....	VI	10
Collar Band, Putting on a.....	VI	2
Collar, Binding a.....	IV	6
Collar, Buster Brown.....	V	5
Collar, Detachable Shirt.....	VI	6
Collar, Fichu.....	VIII	35
Collar, Lining a.....	VII	15
Collar, Lining a Flat.....	V	4
Collar, Notch.....	XI	17
Collar, Sewing on a Lined.....	VIII	21
Collars, Different.....	V	4
Color Tests to Determine Fastness of Colors....	XII	40
Color Wheel, The.....	I	66
Colored or White Fabrics, Removing Fruit Stains from.....	XII	51
Colors, Complementary.....	I	67
Colors for the Blonde Type.....	I	49
Colors for the Blue Eyed Girl with Brown Hair...	I	53
Colors for the Brunette Type.....	I	51
Colors that Combine, Selecting.....	I	68
Combination Underwaist and Drawers, Boys'....	VII	17
Combining Colors.....	I	65
Commercial Pattern, Using a.....	II	2
Commercial Patterns, Ordering.....	I	106
Continuous Facing.....	III	23
Corded Shirrings.....	XII	10

A COMPLETE COURSE IN DRESSMAKING

	Lesson	Page
Cording.....	XII	3
Corner, Binding a.....	IV	5
Corner of Lace, Mitering a.....	III	22
Cornmeal as a Dry Cleaner.....	XII	45
Correct Clothes for Afternoon.....	I	9
Correct Clothes for Business Women.....	I	14
Correct Clothes for Street.....	I	11
Correct Clothes for Travel.....	I	12
Correct Mourning.....	I	15
Correcting the Hang of a One-Piece Dress.....	X	3
Cotton.....	XII	29
Cotton and Woolens, Shrinking of.....	I	115
Cotton, Boiling-Out Test for.....	XII	33
Cotton, Borax Used for Bleaching.....	XII	45
Cotton, Burning Test for.....	XII	32
Cotton, Characteristics of.....	XII	29
Cotton, Creasing Test for.....	XII	36
Cotton Fabrics, Finish and Weighting of.....	XII	39
Cotton, Javelle Water for Bleaching.....	XII	46
Cotton, Judging Grades of.....	XII	37
Cotton, Mercerized.....	XII	29
Cotton, Removing Coffee Stains from.....	XII	50
Cotton, Removing Fruit Stains from.....	XII	51
Cotton in Woolen Cloth, Determining Presence of Cotton, to Distinguish from Linen.....	XII	32 34
Cotton Yarns, Quality of, in Fabrics.....	XII	37
Couch Embroidery.....	XII	13
Cream and Milk Stains, How to Remove.....	XII	55
Creasing Test for Cotton and Linen.....	XII	36
Creasing Test for Wool or Silk.....	XII	36
Crocking in Fabrics, Testing for.....	XII	41
Cross Stitch.....	VIII	7
Cross Stitching Rolled Edges.....	VIII	16
Crosswise Lines, the Effect of.....	I	32
Cuff, Band.....	VII	3
Cuff, Bishop.....	V	5
Cuff, French.....	V	3
Cuff, Men's French.....	VI	5
Cuff, Straight with Narrow Turn-Back.....	V	5
Cuffs, Different.....	V	5
Cuffs, Double.....	VI	5
Cuffs for Tailored Blouse.....	V	3
Cuffs, Frilled.....	VIII	17
Cuffs, Turned Back.....	V	6
Cuffs and Collar for Organdie for Younger Girls.....	I	23
Curved Ruler Used in Sewing.....	I	117
Cutting Table for Sewing.....	III	23

INDEX

	Lesson	Page
Cutting Table, How to Make a.....	I	112
Cutting to Save Goods.....	II	2
Cutting True Bias.....	II	13
D		
Dart, Stitching so it Won't Poke Out.....	VI	9
Darts, How to Lay in.....	V	9
Delicate Fabrics, How to Remove Grease from..	XII	52
Detachable Frill.....	X	12
Detachable Shirt Collars.....	VI	2
Detecting Yarn Dyed and Piece Dyed Fabrics..	XII	39
Different Collars.....	V	4
Different Cuffs.....	V	5
Different Front Closings for Blouse.....	V	3
Different Types for Different People.....	I	22
Distinguishing Linen from Cotton.....	XII	34
Dont's for the Younger Girl.....	I	24
Double Cuffs.....	VI	5
Double-Stitched Seams.....	VIII	4
Double-Stitched Seams.....	I	99
Draping.....	XII	17
Draping a Coat without a Pattern.....	XII	25
Draping a Lining.....	XII	17
Draping a Skirt without a Pattern.....	XII	25
Draping a Waist without a Pattern.....	XII	19
Drawers, a Shaped Facing.....	III	12
Drawers, Boy's.....	VII	17
Drawers, Child's.....	VIII	39
Drawers, Child's Sleeping.....	VIII	40
Drawers, Ladies'.....	III	10
Drawers, with Fullness Across Back.....	III	13
Dress Accessories that Give Height to the Figure	I	35
Dress, Child's Guimpe.....	VIII	15
Dress, Child's Party.....	VIII	33
Dress, Child's Raised Waistline.....	VIII	8
Dress, Child's Straight Hanging.....	VIII	5
Dress, Correcting the Hang of a One-Piece.....	X	3
Dress, Evening.....	I	10
Dress Fabrics, Kinds of Fibres Used in.....	XII	30
Dress Form, Adjustable.....	I	116
Dress Form, Making Use of the.....	I	117
Dress, Infants.....	IV	7
Dress, Lining, Making a.....	X	19
Dress, Long-Waisted.....	X	8
Dress, Overblouse.....	X	19
Dress, Waistline.....	X	13

A COMPLETE COURSE IN DRESSMAKING

	Lesson	Page
Dress, Woman's House.....	X	1
Dress, Woman's Russian Blouse.....	X	18
Dresses, How to Make Women's.....	X	1
Dressmaking and Sewing Equipment.....	I	109
Drop Seat Romper.....	VIII	3
Dry Cleaning.....	XII	41
Dry Cleaning, Blotting Paper Used as an Absorbent in.....	XII	45
Dry Cleaning, Velvets.....	XII	42
Dry Cleaning Colored Materials.....	XII	45
Dry Cleaning Powder or Soap.....	XII	41
Dry Cleaning Spots or Stains with Chalk.....	XII	45
Dye Stains, Removing.....	XII	65
Dyed Materials, Restoring Color to.....	XII	57
Dyeing Materials, Three Methods of.....	XII	57
E		
Easiest Way of Finishing a Collar; Boy's Blouse..	VII	2
Easiest Way of Making a Lap-Filled Seam.....	VI	4
Easy Made Scallops.....	XII	2
Edge, Pointed.....	XII	1
Edge, Scalloped.....	XII	2
Edge, Taping an.....	IX	2
Edging.....	IX	2
Edging, Sewing on Lace and Embroidery.....	III	10 & 12
Effect of Moisture upon Silk.....	XII	34
Effective Treatment for Old Stains.....	XII	55
Elastic Bands, Usefulness of.....	I	119
Elastic Waistband for Camisole.....	III	4
Embroidery, Couch.....	XII	13
Embroidery, Design for Underwear.....	III	19
Embroidery Stitches for Blouse Trimming:.....	V	15
Envelope Chemise.....	III	16
Equipment, Dressmaking and Sewing.....	I	109
Ether, an Organic Solvent for Removing Stains..	XII	46
Eton Jacket.....	XI	22
Evening Frocks.....	X	21
Evening Wrap, Woman's.....	XI	27
Everything a Layette Ought to Include.....	IV	1
Extension, Finishing Placket with.....	IX	7
Extension, for Men's Pajamas, Making the.....	VI	14
Extension for Sleeve Vent.....	VI	3
Extension for Boy's Bloomers, How to Cut.....	VII	5
F		
Fabrics, Finish and Weighting of.....	XII	38
Fabrics, How to Remove Grease from Delicate...	XII	52

INDEX

	Lesson	Page
Fabrics, Kind of Fibers Used in Dress.....	XII	30
Facing, Bias.....	VIII	10
Facing Bottom of Sleeve.....	X	6
Facing, Continuous.....	III	23
Facing for Front of Men's Shirt.....	VI	1
Facing for Men's Bathrobe.....	VI	7
Facing from Edges of Blouse.....	V	4
Facing Left Front of Boy's Trousers.....	VII	5
Facing on a Collar.....	IV	6
Facing Shaped Drawers.....	III	12
Facing the Armholes.....	X	19
Facing the Front of a Coat.....	XI	7
Facing the Top of a Boy's Trousers.....	VII	9
Facing for Boy's Underwear.....	VII	18
Facings, Shaped.....	IV	13
Fashion Design for the Small Girl.....	I	23
Fashion Magazine, How to Use.....	I	18
Fast Colored or White Fabrics, Removing Fruit Stains from.....	XII	51
Fastenings, Tape.....	IV	4
Featherboning a Seam.....	III	9
Feather Stitching.....	IV	4
Felling.....	III	3
Felling.....	I	93
Fiber Content of Cloth, Simple Ways of Testing.....	XII	30
Fibers, Animal and Vegetable.....	XII	31
Fichu Collar.....	VIII	35
Finish and Weighting of Fabrics.....	XII	38
Finishing a Coat Sleeve.....	XI	9
Finishing a Coat without a Lining.....	XI	34
Finishing a Petticoat Placket.....	III	24
Finishing an Insert Pocket.....	IX	9
Finishing Fur.....	XII	14
Finishing the Armhole.....	VIII	11
Firmness of Weave, Judging Quality of Fabrics by.....	XII	35
Fitted Lining, How to Drape A.....	XII	17
Fitting a Broad Chest and Narrow Back.....	V	16
Fitting a High Abdomen.....	IX	6
Fitting a Waist Pattern.....	V	10
Fitting Sloping Shoulders.....	V	15
Fitting Square Shoulders.....	V	16
Fitting Wide Back and Narrow Chest.....	V	16
Florid Complexion, Blue-Green Tabooed for.....	I	62
Floss, Machine Stitching with Heavy.....	XII	13
Flounce, Quick Way of Sewing on a.....	III	26
Fly; for Boys' Button-on Trousers.....	VII	10
Folds, Turned into Points for Trimming.....	XII	1

A COMPLETE COURSE IN DRESSMAKING

	Lesson	Page
Foliage Stains, How to Remove.....	XII	52
Foreign Substances, Use of in Fabrics.....	XII	38
Foundation Pattern, How to Use a.....	IX	13
French Cuffs.....	V	3
French Knots.....	III	20
French Seams.....	II	7
Fresh Coffee Stain, Removing from Cotton and Linen.....	XII	50
Frill, Detachable.....	X	12
Frill, Finishing Outer Edge of.....	VIII	16
Fripped Closing.....	V	4
Fripped Cuff.....	VIII	17
Frock, Evening.....	X	21
Frock, Simplicity the Keynote for Young Girl's..	I	23
Frogs for Men's Bathrobe.....	VI	11
Fruit Stains, Removing.....	XII	51
Fullness—Three Ways of Taking Out of Waist...	V	9
Fur Trimming, How to Apply.....	XII	14

G

Gasoline as a Solvent for Removing Stains.....	XII	46
Gasoline as an Explosive in Dry Cleaning.....	XII	41
Gathered Insets.....	XII	7
Gathering.....	II	9
Gathering the Back of a Man's Shirt.....	VI	2
Gathering the Lower Edge of a Man's Sleeve....	VI	4
Gertrude Petticoat, Infant's.....	IV	2
Girdles.....	XII	11
Girl's Top Coat.....	XI	34
Golf Clothes.....	I	7
Gored Skirt.....	IX	5
Grades of Silk.....	XII	33
Grass Stains, How to Remove.....	XII	52
Gravies and Juices of Meat, How to Remove....	XII	54
Grey Hair, Clothes for the Women with.....	I	57
Grease, Solvent Used for Dry Cleaning.....	XII	52
Grease Stains, How to Remove.....	XII	52
Guide for Plaiting a Skirt.....	VIII	27
Guide for Spacing Tucks.....	VIII	37
Guide for Turning a Hem.....	III	3
Guimpe Dress, Child's.....	VIII	15

H

Hanging Your Skirt.....	IX	12
Hats, Becoming for the Young Woman of Medium Build.....	I	30

INDEX

	Lesson	Page
Hats for the Stout Young Women.....	I	34
Helpful Hints for the Older Woman.....	I	46
Helpful Hints for the Short Woman.....	I	35
Helpful Hints for the Slim Young Girl.....	I	23
Helpful Hints for the Stout Young Girl.....	I	24
Helpful Hints for the Stout Younger Woman.....	I	32
Helpful Hints for the Tall Woman.....	I	20
Helpful Hints for the Thin Woman.....	I	43
Helpful Hints for the Young Woman of Medium-Build.....	I	28
Hem, Guide for Turning a.....	III	3
Hemmed Closing.....	V	2
Hemming.....	II	8
Hems, Applied.....	VIII	21
Hemstitching with an Ordinary Sewing Machine.....	XII	16
High Abdomen; Fitting a.....	IX	6
Hook and Eye Closing.....	III	7
Hot or Cold Water Used in Laundering Silk or Wool.....	XII	44
House Dress, Woman's.....	X	1
How Cotton is Mercerized.....	XII	29
How to Acquire a Straight Silhouette.....	I	25
How to Apply Trimming on Stout Young Girl's Dress.....	I	25
How to Cut Extension for Boy's Bloomers.....	VII	5
How to Drape.....	XII	17
How to Drape a Coat.....	XII	21
How to Drape a Fitted Lining.....	XII	17
How to Drape a Skirt.....	XII	24
How to Identify Silk in a Wool Mixture.....	XII	33
How to Make a Cutting Table.....	I	112
How to Make a Sleeve Board.....	I	114
How to Make Javelle Water.....	XII	46
How to Piece.....	II	6
How to Remove Fruit Stains from Silk or Wool..	XII	51
How to Remove Grease Stains.....	XII	52
How to Remove Ink.....	XII	53
How to Remove Iodine Stains.....	XII	54
How to Remove Iodine Stains on Wash Materials	XII	54
How to Remove Mildew.....	XII	54
How to Remove Mud Stains.....	XII	55
How to Remove Fruit Stains.....	XII	51
How to Remove Specific Spots and Stains.....	XII	48
How to Remove the Shine on Surface of Goods...	XI	4
How to Stitch a Dart so it Won't Poke Out.....	VI	9
How to Study.....	I	120
How to Take Measurements.....	I	106

A COMPLETE COURSE IN DRESSMAKING

	Lesson	Page
How to Test Materials.....	XII	28
Hydrogen Peroxide as a Bleaching Agent.....	XII	46
Hydrogen Peroxide Used for Removing Ink Stains.....	XII	53
Hygienic Materials for a Layette.....	IV	1
Hygienic Styles for a Layette.....	IV	2

I

If You are Tall, Suggestions.....	I	40
If You are Thin, Suggestions.....	I	43
In-Between Girl, Colors for the.....	I	53
Inconspicuous Colors for Stout People.....	I	64
Individuality, How to Suit Your.....	I	2
Infants' Caps.....	IV	12
Infants' Cloaks.....	IV	10
Infants' Clothes; How to Make.....	IV	1
Infants' Dress.....	IV	7
Infants' Gertrude Petticoat.....	IV	2
Infants' Kimona.....	IV	5
Ink, Different Remedies for Absorbing.....	XII	53
Ink Stains, How to Remove.....	XII	53
Insertion, How to Insert.....	III	21
Inset, Medalion, How to Sew on.....	III	21
Inset Pocket Finishing.....	IX	9
Insets, Gathered.....	XII	7
Insets, Plaited.....	XII	10
Insets, Tucked and Shirred.....	XII	6
Interlining a Woman's Coat.....	IX	14
Iodine Stains, How to Remove.....	XII	54
Ironing Board.....	I	113
Iron Rust Stains.....	XII	54

J

Jacket, Eton.....	XI	22
Jacquered Silk Dress, Good Style for.....	X	8 & 9
Jarring Notes in Color Combination.....	I	66
Javelle Water for Bleaching Cotton or Linen.....	XII	46
Javelle Water for Cleaning.....	XII	47
Javelle Water, Making of.....	XII	46
Javelle Water, Used in Cleaning for Cotton or Linen only.....	XII	46
Jersey Dress, Pretty Style for a.....	X	13
Jersey Petticoat, Cotton or Silk Material for....	III	23
Jersey, Wool, Desirable Material for the Thin Woman.....	I	43
Jewelry, Suggestions for the Use of.....	I	24
Joining a Child's Skirt to Waist.....	VIII	19

INDEX

	Lesson	Page
Joining Back of Trousers at Top to Waistband..	VII	19
Joining Back Trouser Section of Child's Romper.	VIII	5
Joining Collar to Neck of Girl's Blouse.....	VIII	21
Joining Extension to Right Front of Boy's Trousers	VII	5
Joining Flounce to Petticoat.....	III	26
Joining Inner Leg Seams, Men's Pajamas.....	VI	14

K

Keeping the Sewing Machine in Order.....	I	72
Kimono, Infants'.....	IV	5
Kimono, Infants', Binding Edges.....	IV	5
Kimono, Infants', French Seam for Underarm....	IV	5
Kimono Pattern, Infants'.....	IV	5
Kimono Pattern, Layout for.....	IV	5
Kimono Sleeves, Infants.....	IV	2
Kimono Style, Girl's Dress.....	VIII	5
Kind of Fibers Used in Cloth, Determining:.....	XII	30
Knee-Bank, Closing.....	VII	9
Knickerbockers, Layout for.....	VII	4
Knots, French.....	III	20
Knowing Whether Material will Give Good Service	XII	28

L

Lace and Embroidery Edging, Sewing on.....	III	10 & 12
Lace Edging, Joining.....	III	19
Lace Veils, How to Clean.....	XII	43
Lapel, Peak.....	XI	22
Lap-Felled Seam.....	I	101
Lap-Felled Seams.....	V	2
Lard, for Removing Tar and Oil Stains.....	XII	56
Laundering, to Remove Stains.....	XII	43
Layette, Hygienic Material for a.....	IV	1
Layette, Hygienic Styles for a.....	IV	2
Layette, What it Should Include.....	IV	1
Laying in Darts.....	V	9
Laying Out the Pattern, Best Way of.....	II	3
Lazy Daisy Stitch.....	III	19
Lemon Juice and Salt for Removing Iron Rust..	XII	54
Lemon Juice, Good for Removing Stains.....	XII	54
Length of Back, Measuring.....	I	108
Length of Front, Measuring.....	I	108
Length to Floor.....	I	109
Lengthening a Sleeve Pattern.....	V	13
Lengthening or Shortening a Coat Pattern.....	XI	3
Light Test to Determine Quality of Fabrics.....	XII	36
Linen, Borax Used for.....	XII	46

A COMPLETE COURSE IN DRESSMAKING

	Lesson	Page
Linen, Boiling Test for.....	XII	34
Linen, Burning Test for.....	XII	34
Linen, Creasing Test for.....	XII	36
Linen, Javelle Water for Bleaching.....	XII	46
Linen, Removing Coffee Stains from.....	XII	50
Linen, Source of.....	XII	30
Linen, to Distinguish from Cotton.....	XII	34
Linen, Yarn Dyed.....	XII	40
Lingerie; Blouse.....	V	13
Lining a Belt.....	V	7
Lining a Collar.....	VII	15
Lining a Dress.....	X	19
Lining a Flat Collar.....	V	4
Lining a Girl's Belt.....	VIII	28
Lining a Jumper.....	VIII	17
Lining a Pocket, so the Lining won't Show.....	VI	10
Lining Material for Collar and Pocket.....	VI	10
Long Waisted Dress.....	X	8
Loops; Buttonhole.....	XI	29
Looped Trimming.....	XII	10

M

Machine Stitching with Heavy Floss.....	XII	13
Making a Dress Lining.....	X	19
Making a Sleeve Larger.....	V	13
Making a Sleeve Smaller at the Bottom.....	V	12
Making a Sleeve Larger at the Top.....	V	11
Making a Straight Gathered Girl's Skirt.....	VIII	12
Making Belt for Ladies' Drawers.....	III	13
Making the Chemise.....	III	18
Making the Coat with Canvas Interlining.....	XI	5
Making the Fly for Boy's Button-on-Trousers....	VII	10
Making the Nightgown.....	III	21
Making the Petticoat.....	III	23
Making Use of the Dress Form.....	I	117
Materials, Desirable for Stout Young Woman...	I	34
Material for Collar and Pocket Lining.....	VI	10
Material Loops Instead of Buttonhole.....	XI	29
Materials not Advisable for Stout Young Woman.	I	34
Materials, Testing.....	XII	28
Materials, Washable, Removing Grease from....	XII	52
Materials, Wool, Finish and Weight of.....	XII	38
Measurement for the Bust.....	I	106
Measurement for the Hip.....	I	108
Measurement for the Neck.....	I	107
Measurement for the Waist.....	I	108

INDEX

	Lesson	Page
Measurements, Rule for, in Sewing.....	I	106
Measurements, Tape, Various Kinds of.....	I	117
Measuring Length of Back.....	I	108
Measuring Length of Front.....	I	108
Measuring Length to Floor.....	I	109
Measuring the Width of Back.....	I	107
Meat Juices and Gravies, Removing.....	XII	54
Medallion, How to Sew on an Inset.....	III	21
Men's Bathrobe.....	VI	6
Men's Clothes, How to Make.....	VI	1
Men's French Cuff.....	VI	5
Men's Shirt.....	VI	1
Men's Pajamas.....	VI	12
Mercerized Cotton.....	XII	29
Method of Dyeing Material, Determining their Value.....	XII	57
Methods of Applying Reagents.....	XII	45
Middy and Plaited Skirt, Child's.....	VIII	29
Middy Blouse, Child's.....	VIII	31
Mildew, How to Remove.....	XII	54
Milk and Cream Stains, How to Remove.....	XII	55
Milk, How to Remove Ink Stains with.....	XII	55
Mitering a Corner of Lace.....	III	22
Moisture, Effect of, on Silk.....	XII	34
Mourning, Correct.....	I	15
Mourning—First.....	I	16
Mourning—Periods of.....	I	15
Mourning—Second.....	I	18
Mud Stains, How to Remove.....	XII	55
N		
Narrow Hem, How to Turn.....	II	7
Neatest Way to Finish Lower Edge of Sleeve....	VI	9
Neck, Armhole and Underarm Closing.....	X	11
Neck-Band for Man's Shirt.....	VI	2
Neck, "U" Shaped, for the Older Woman.....	I	47
Neck, "V" Shaped; Recommended for the Stout Woman.....	I	33
Nightgown, Child's.....	VIII	42
Nightgown, Woman's.....	III	20
Nobby Sailor Suit, Boys.....	VII	14
Norfolk Coat, Woman's.....	XI	17
Notch Collar.....	XI	17
O		
Oblong Facing for Lower Portion of Chemise....	III	18
Obtaining Satisfactory Results in Dry Cleaning..	XII	41

A COMPLETE COURSE IN DRESSMAKING

	Lesson	Page
Oil Cloth, Table, for Sewing Equipment.....	I	113
Old Stains, Treatment of.....	XII	55
One-Piece Dress, Correcting the Hang of.....	X	4
Open Seam.....	I	95
Open Seams.....	VIII	17
Opera Wrap.....	XI	27
Orange and Copper Shades for the Brunette Type	I	52
Ordinary Closing.....	VIII	9
Ordinary Dress Form.....	I	116
Ordering Commercial Pattern.....	I	106
Organdie Collar and Cuffs for Younger Girls.....	I	23
Organdie; Finish for Collars; Cuffs and Tunics...	XII	1
Organic Solvents to be Used in Cleaning.....	XII	46
Origin of Artificial Silk.....	XII	30
Original Ideas for Trimming.....	XII	1-16
Outline Stitch.....	III	20
Overblouse Dresses.....	X	19
Overcasting.....	III	15
Oxalic Acid, How to Remove Ink Stains with....	XII	49
Oxalic Acid, Removing Iron Rust with.....	XII	54
Oxalic Acid, Used for Removing Stains.....	XII	46

P

Padded Buttonhole.....	XI	11
Padding Stitches.....	XI	8
Paint and Varnish Stains, How to Remove.....	XII	55
Pajamas, Men's.....	VI	12
Paper, Blotting, as an Absorbent in Dry Cleaning	XII	45
Paraffin Stain, How to Remove.....	XII	50
Party Dress, Child's.....	VIII	33
Part Wool and Part Cotton Goods; Testing.....	XII	34
Patch Pockets.....	II	11
Pattern, Best Way of Laying Out the.....	II	3
Pattern for Pointed Facing.....	VI	3
Pattern, Using a Commercial.....	II	1
Pattern, Using a Foundation.....	IX	13
Peak Lapel.....	XI	22
Peplum, Coat with.....	XI	12
Perpendicular Lines for Accentuating Height....	I	33
Perspiration, to Restore Color of Fabrics Changed by.....	XII	56
Petite Figure, Suggestions for.....	I	36
Petticoat, Child's.....	VIII	38
Petticoat Placket, Finishing a.....	III	24
Petticoat, Woman's.....	III	23
Piece Dyed Cotton Materials.....	XII	40

INDEX

	Lesson	Page
Piecing.....	II	6
Pin Tucks.....	IV	7
Placket with Extension.....	IX	7
Placket with Underlap.....	IX	3
Plaquettes, Skirt.....	IX	3 & 7
Plain Blouse Pattern; Adding a Tuck to a.....	V	9
Plain Blouse Pattern; Adding a Yoke to a.....	V	7
Plain Blouse Pattern; Adding Fullness to a.....	V	8
Plain Seams.....	II	7
Plait, How to Add a.....	V	9
Plaited Insets.....	XII	10
Plaited Skirt; Child's.....	VIII	29
Plaiting a Skirt; Guide for.....	VIII	25-27
Pocket Inset.....	IX	9
Pocket, Lining a.....	VI	10
Pocket, Patch.....	II	11
Pocket, Skirt.....	IX	8
Pocket, Slashed.....	VII	6
Pocket, with Flap.....	XI	32
Pointed Edge.....	XII	1
Precautions for Removing Blood Stains.....	XII	49
Precautions Necessary in Laundering Fabrics....	XII	47
Pressing.....	I	115
Pressing Essential in Sewing.....	I	115
Pretty Colors for the Woman with Gray Hair....	I	58
Printed Cotton Material.....	XII	45
Proper Sewing Equipment.....	I	109
Proper Thread and Needles for Hand Sewing.....	I	76
Proper Thread and Needles for Sewing Machine..	I	76
Protein or Animal Fibre in Woven Cloth; Dis- tinguishing.....	XII	39
Pulling Test for Determining Firmness of Fabrics	XII	35
Putting on a Collarband.....	VI	2
Putting on a Waistband.....	II	10

Q

Quaint Collar Combination for the Woman with Gray Hair.....	I	47
Quaint Trimmings for Different Dresses.....	XII	1-16
Quality Cotton Yarns in Fabrics.....	XII	37
Quality Fashions.....	X	8; 9; 13; 19 & 20
Quality of Silk Yarns in Fabrics.....	XII	37
Quality of Yarns in Fabrics.....	XII	36
Quartering Material for Gathers.....	III	25
Queen-Stitch—An Effective Embroidery Pattern.	XII	13

A COMPLETE COURSE IN DRESSMAKING

	Lesson	Page
Questions about Draping Plainly Answered.....	XII	17
Quick Finish for a Belt.....	VIII	14
Quick Way of Sewing on a Flounce.....	III	26
Quilling.....	XII	8
Quite Attractive Child's Dress.....	VIII	20

R

Raglon Coat; Boys'.....	XI	31
Raised Waistline, Allowing for a, in a Skirt.....	IX	14
Raised Waistline, Dress, Child's.....	VIII	8
Reagents, Action of on Animal Fibres.....	XII	44
Reagents, Action of on Vegetable Fibres.....	XII	44
Recognizing Good Wool.....	XII	35
Regulating the Sewing Machine Tensions.....	I	73
Reinforcing the Armhole.....	III	10
Reinforcing the Yoke.....	XI	28
Removing Stains.....	XII	43
Removing Blood Stains.....	XII	49
Removing Coffee Stains from Cotton or Linen...	XII	50
Removing Iodine Stains.....	XII	54
Removing Iron Rust Stains.....	XII	54
Removing Grease Stains from Cotton and Linen with Alcohol.....	XII	52
Removing Mildew.....	XII	54
Removing Milk and Cream Stains.....	XII	55
Removing Paint and Varnish Stains.....	XII	55
Removing Stains with Vinegar.....	XII	46
Removing Tar and Road Oil Stains.....	XII	56
Removing Tea Stains.....	XII	56
Renovating Notes.....	XII	41
Ribbon Binding.....	IV	5
Ribbon Trimming.....	XII	10
Rickrack Braid, Sewing on.....	XII	3
Riding Habits.....	I	8
Road Oil, Tar, Stains, How to Remove.....	XII	56
Rolled Edges, Cross Stitching.....	VIII	16
Romper Drop Seat.....	VIII	3
Romper with Underleg Opening.....	VIII	1
Ruffles, Cutting Crosswise of Material for Flare..	III	23
Rugs or Course Materials, Removing Grease from	XII	52
Ruler, Curved, Used in Sewing.....	I	117
Running Stitch.....	II	9
Russian Blouse Dress, Women's.....	X	18
Russian Blouse Suit, Boy's.....	VII	12
Rust Stains, Iron, How to Remove.....	XII	54

INDEX

S	Lesson	Page
Sailor Suit; Boy's.....	VII	14
Sallow Complexion, Appropriate Colors for a.....	VII	14
Scalloping the Lower Edge of a Skirt.....	VIII	39
Scallops, Easy Made.....	XII	1
Seam, Double Stitched.....	VIII	4
Seam, Featherboning a.....	III	9
Seam, French and Plain.....	II	7
Seam, Lap-Filled.....	V	2
Seam, Slot.....	IX	2
Seams and their Uses, Double Stitched Seams.....	I	95
Seams and their Uses, French Seams.....	I	99
Seams and their Uses, Lap-Filled Seams.....	I	97
Seams and their Uses, Open Seams.....	I	95
Seams and their Uses, Slot Seam.....	I	104
Seams in a Skirt, to Change the Placing of.....	IX	14
Seashell Scallops.....	XII	9
Selecting an Easy to Fit Brassiere Style.....	III	5
Selecting Colors that Combine.....	I	66
Semi-Fitting Coat, Ladies'.....	XI	2
Sewing a Skirt to Grosgrain Belting.....	IX	4
Sewing Equipment.....	I	109
Sewing in a Sleeve.....	V	2
Sewing, Hand.....	I	88
Sewing Machine Attachments.....	I	77
Binder.....	I	81
Corder.....	I	85
Edge Stitcher.....	I	84
Narrow Hemmer.....	I	77
Quilter.....	I	86
Ruffler.....	I	83
Tucker.....	I	82
Wide Hemmer.....	I	79
Sewing Machine, Keeping in Order.....	I	72
Sewing Machine, Proper Thread and Needles for.....	I	76
Sewing Machine—Tension—Regulating.....	I	73
Sewing Machine, Your.....	I	72
Sewing on a Lined Collar.....	VIII	21
Sewing on a Medallion.....	III	21
Sewing on Coat Buttons.....	XI	11
Sewing on Embroidered Edging.....	III	10
Sewing on Lace Edging by Hand.....	III	12
Sewing on Lace Insertion in a Fancy Design.....	III	21
Sewing on Rickrack Braid.....	XII	3
Sewing Room, Equipment for.....	I	109
Sewing Test for Judging Quality of Fabrics.....	XII	36
Shaped Facings.....	IV	13
Shawl Collar.....	XI	13

A COMPLETE COURSE IN DRESSMAKING

	Lesson	Page
Shears, Three Sizes Used in Sewing.....	I	110
Shield for Boy's Sailor Suit.....	VII	16
Shirred Insets.....	XII	6
Shirring, Silk.....	XII	9
Shirring, Tucked.....	XII	10
Shirrings, Applied.....	XII	7
Shirrings, Corded.....	XII	10
Shirrings for Child's Party Dress.....	VIII	35
Shirt, Men's.....	VI	1
Shoody, All About.....	XII	37
Short Stout Women's Dress, Long Lines for.....	I	36
Shortening a Sleeve.....	V	14
Shoulder, Armhole and Underarm Closing.....	X	11
Shoulder Straps, Adjusting.....	III	5
Shrinking, the Best Method of.....	I	115
Shrinking of Cotton and Woolens.....	I	115
Side Pocket for Boy's Trousers.....	VII	8
Simple Embroidery Stitches.....	V	15
Simple Ways of Testing the Fiber Content of Cloth	XII	30
Silk, All About.....	XII	29
Silk, Artificial.....	XII	30
Silk and Artificial Silk.....	XII	33
Silk, Bleaching with Hydrogen Peroxide.....	XII	46
Silk, Characteristics of.....	XII	29
Silk, Creasing Test for.....	XII	36
Silk, Effect of Moisture upon.....	XII	34
Silk Fabrics Tested for Fastness to Wear.....	XII	35
Silk, Grades of.....	XII	29
Silk, How to Identify in a Cotton Mixture.....	XII	33
Silk, How to Identify in a Wool Mixture.....	XII	33
Silk Materials, Finish and Weighting of.....	XII	38
Silk, Removing Blood Stains from.....	XII	49
Silk, Removing Coffee Stains from.....	XII	50
Silk, Removing Fruit Stains from.....	XII	51
Silk, Restoring Color Destroyed by an Alkali....	XII	49
Silk, Source of.....	XII	29
Silk Yarn, Burning Test for.....	XII	32
Silk Yarns in Fabrics.....	XII	33
Skirt, Circular.....	IX	1
Skirt, Draping without a Pattern.....	XII	25
Skirt for the Stout Younger Woman.....	I	34
Skirt, Gored.....	IX	5
Skirt, How to Make Women's.....	IX	1
Skirt, How to Turn Lower Edge Evenly.....	IX	12
Skirt Pattern, Foundation for.....	IX	13
Skirt Plackets.....	IX	3 & 7
Skirt Plaited, Child's.....	VIII	29

INDEX

	Lesson	Page
Skirt Pocket.....	IX	8
Skirt Sewing to Belting.....	IX	4
Skirt to Scallop the Lower Edge of a.....	VIII	39
Skirt, Two-Piece.....	IX	8
Skirt, with Yoke.....	IX	10
Slashed Closings, Children's.....	VIII	2 & 42
Slashed Closings, Infant's.....	IV	8
Slashed Pocket.....	VII	6
Sleeping Drawers, Child's.....	VIII	40
Sleeves, Close-Fitting, for Stout Women's Styles..	I	33
Sleeves for Men's Bathrobe.....	VI	8
Sleeves, Lengthening and Shortening.....	V	14
Sleeves, Making Larger or Smaller.....	V	12 & 13
Sleeve Vent.....	VI	3
Slip-on Apron.....	II	11
Slip Stitching.....	IV	3
Sodium Bicarbonate (Baking Soda), an Alkali for Removing Stains.....	XII	46
Solvents Organic, for Cleaning Spots and Stains..	XII	46
Solvents Used for Cleaning Spots and Stains....	XII	46
Sour Milk, Used to Remove Mildew Stains.....	XII	54
Source of Linen.....	XII	30
Source of Silk.....	XII	29
Source of Wool.....	XII	28
Spacing Tucks, a Guide for.....	VIII	37
Specific Spots and Stains, How to Remove.....	XII	48
Sponging to Remove Stains.....	XII	47
Sport, Correct Clothes for.....	I	5
Spotting to Remove Stains when Using Chemical Reagents.....	XII	48
Starch as a Dry Cleaner.....	XII	45
Stay Belt for Boy's Trousers.....	VII	11
Staying a Seam.....	VII	9
Staying the Bottom of a Coat.....	XI	9
Stitch, Back.....	VIII	31
Stitch, Blanket.....	VIII	7
Stitch, Cat.....	IV	11
Stitch, Cross.....	VIII	7
Stitch, Lazy-Daisy.....	III	19
Stitch, Outline.....	III	20
Stitch, Running.....	II	9
Stitch, Running, Hand.....	I	88
Stitches, Padding.....	XI	8
Stitching a Dart at the Neck of Men's Bathrobe.	VI	9
Stitching a Turn-Back Cuff to Lower Edge of Short Sleeve.....	V	6
Stitching, Blind, Hand.....	I	94

A COMPLETE COURSE IN DRESSMAKING

	Lesson	Page
Stitching Braid, Collar of Boy's Sailor Suit.....	VII	14
Stitching Collar and Pocket of Men's Bathrobe...	VI	10
Stitching, Feather.....	IV	4
Stitching, Pocket to Apron.....	II	11
Stitching, Sheer Materials.....	V	14
Stitching with Heavy Floss.....	XII	13
Stout Young Girls, Dress Material for.....	I	25
Stout Young Woman, Styles for Accentuating Height of.....	I	32
Straight Cuff with Narrow Turn-Back.....	V	5
Straight Cuffs.....	V	6
Straight Hanging Dress, Child's.....	VIII	5
Straps for Men's Bathrobe.....	VI	11
Street, Correct Clothes for.....	I	11
Strong Acids, Use for in Testing Materials.....	XII	31
Study Your Type before Selecting Your Clothes..	I	22
Style Suggestions for Stylish People.....	I	1
Styles Suitable for the Young Woman of Medium Build.....	I	28
Styles Suitable for the Slim Young Girl.....	I	23
Styles Suitable for the Stout Young Girl.....	I	24
Styles Suitable for the Thin Woman.....	I	43
Styles Suitable for the Older Woman.....	I	46
Styles Suitable for the Stout Younger Woman....	I	32
Styles Suitable for the Short Woman.....	I	35
Styles Suitable for the Tall Woman.....	I	40
Substitutes for Regular Dressmaking Equipment.	I	109
Substitutes for the Sewing Room.....	I	109
Suit, Boy's Russian Blouse.....	VII	12
Suit, Boy's Sailor.....	VII	14

T

Table, Cutting for Sewing.....	I	112
Taffeta Silk, a Suitable Material for Young Girl's Frock.....	I	23
Tailored Blouse.....	V	1
Tailor's Tacks.....	XII	15
Tailor's Wax.....	I	118
Taking the Bust Measure.....	I	106
Taking the Hip Measure.....	I	108
Taking the Neck Measure.....	I	107
Taking the Waist Measure.....	I	108
Tall Figures, Suggestion for.....	I	40
Tape Fastenings.....	IV	4
Tape Measures, Various kinds of.....	I	117
Taping an Edge.....	IX	2

INDEX

	Lesson	Page
Tar, Road Oil Stains, How to Remove.....	XII	56
Tassel and Braid Trimming.....	XII	10
Tea Stains, How to Remove.....	XII	56
Tennis Clothes.....	I	6
Test for Piece Dyed Fabrics.....	XII	39
Testing Cloth with Thumb Nail.....	XII	36
Testing Cotton and Linen by Creasing.....	XII	35
Testing Cotton Materials to Detect Method of Dyeing.....	XII	40
Testing Fabrics by Sewing Test.....	XII	36
Testing Fabrics for Firmness of Weave.....	XII	35
Testing Linen and Cotton by Tearing.....	XII	34
Testing Materials.....	XII	28
Testing Part Wool and Part Cotton Goods.....	XII	32
Testing Silk Fibre by Creasing.....	XII	35
Testing Silk Materials for Weight.....	XII	38
Testing Wool and Silk Fabrics for Fastness to Water.....	XII	41
Testing Wool and Silk Fabrics for Fastness to Cracking.....	XII	41
Testing Wool and Silk Fabrics for Fastness to Washing.....	XII	41
Testing Wool Fabric by Creasing.....	XII	35
Test Questions.....	I	120
The Easiest Way to Lay Tucks in Sheer Material	VIII	36
The Simplest Way of Making a Band-Cuff.....	VII	3
Thin Figures, Style Suggestions for.....	I	43
Thread and Needles, Proper for Hand Sewing....	I	76
Thread and Needles, Proper for Sewing Machine.	I	76
Three Inch Hem.....	II	8
Three Methods for Removing Stains.....	XII	43
Three Things of Importance when Selecting a Dress.....	I	2
Three Ways of Fitting a Waist Pattern.....	V	9
Three Ways of Testing Difference between Silk and Artificial Silk.....	XII	33
Thumb Nail Test for Quality of Fabric.....	XII	36
To Add Pin Tucks, Using a Plain Pattern.....	IV	7
To Change the Placing of the Seams in a Skirt...	IX	14
To Make a Coat Pattern Longer or Shorter Waisted	XI	3
To Make a Skirt Pattern Higher Waisted.....	IX	15
To Make a Skirt Pattern Larger or Smaller at Bottom.....	IX	14
To Make Boy's Button-on Trousers.....	VII	10
To Prevent the Neck from Stretching.....	II	14
To Scallop the Lower Edge of a Skirt.....	VIII	39

A COMPLETE COURSE IN DRESSMAKING

	Lesson	Page
To Take Out Fullness of Basque Waist at Underarm Seam.....	V	10
Top Coat, Women's.....	XI	25
Tracing Wheel, Steel, Used in Sewing.....	I	118
Travel, What to Wear When you.....	I	12
Treating a Garment Spotted with an Acid Substance	XII	48
Treating a Garment Spotted with an Alkali Substance.....	XII	49
Trimming, Braid and Tassel.....	XII	10
Trimming, Buttons as.....	XII	12
Trimming, Embroidery Stitches for Blouse.....	V	15
Trimming, Folds Turned into Points for.....	XII	1
Trimming for Blouse.....	XII	16
Trimming for Children's Clothing.....	XII	16
Trimming for Cloth Dress.....	XII	12
Trimming for Cotton Dress.....	XII	1
Trimming for Silk Dress.....	XII	7
Trimming for Suits.....	XII	14
Trimming for Underwear.....	XII	16
Trimming, How to Apply on Stout Young Girl's Dress.....	I	25
Trimming, Looped.....	XII	10
Trimming, Organ Plaited Ribbon.....	XII	12
Trimming, Ribbon.....	XII	10
Trousers, Boy's.....	VII	4
Trousers, Boy's Button-on.....	VII	10
Tucked Banding.....	XII	6
Tucked Insets.....	XII	6
Tucked Shirring.....	XII	10
Tucks, Pin.....	IV	7
Turn-back Cuffs.....	V	6
Turpentine as an Organic Solvent for Removing Stains.....	XII	46
Turpentine, for Removing Paint and Varnish Stains.....	XII	55
Two-Piece Skirt.....	IX	8
Two-Piece Sleeve.....	X	10
Two Ways of Laying Out a Pattern.....	II	3
Types, for Different People.....	I	22

U

U-Shaped Neck for the Older Woman.....	I	47
Underarm Closing.....	X	11
Underleg Romper Closing.....	VIII	2
Underwaist, Boy's.....	VII	17
Underwear, Embroidery Design for.....	III	19

INDEX

	Lesson	Page
Underwear, How to Make.....	III	1
Using a Commercial Pattern.....	II	1
Using a Foundation Pattern to Copy New Styles.	IX	13
V		
V-Neck Outline Best for Stout Women's Styles..	I	33
V-Shaped Yoke.....	III	15
Valenciennes Lace Appropriate for Edging.....	III	19
Variety of Dyes as Affected by Cleaning.....	XII	45
Various Agents for Removing Spots and Stains....	XII	43
Various Finishes for Soft Skins.....	XII	38
Various Methods of Applying Reagents in Cleaning	XII	45
Various Methods of Applying Trimming.....	XII	2 & 3
Varnish and Paint Stains, How to Remove.....	XII	55
Vegetable Fibers, Action of Reagents on.....	XII	45
Vegetable Fibers, Characteristics of.....	XII	31
Veiling, Tulle, Beautiful Material for Evening Frock.....	X	21
Veils, How to Clean.....	XII	43
Velour Used for Piping on Cloth Dresses.....	XII	12
Velvet Coats, Finishing.....	XI	35
Velvets, How to Clean and Freshen.....	XII	42
Vent in a Sleeve, Finishing the.....	VI	3
Vest.....	VIII	36
Vinegar Used for Removing Stains.....	XII	46
W		
Waist Draping, without a Pattern.....	XII	19
Waist Pattern, Fitting a.....	V	10
Waistband, Boy's.....	VII	4
Waistband, Elastic.....	III	4
Waistband for Apron.....	II	9
Waistband for Boy's Blouse.....	VII	4
Waistband, Putting on a.....	III	10
Waistband, Strings.....	II	10
Waistline Apron.....	II	7
Waistline Dress.....	X	13
Washable Material, Removing Chocolate or Cocoa from.....	XII	50
Washable Material, Removing Grease from.....	XII	52
Water, Hot and Cold for Laundering Wool and Silk.....	XII	44
Water, as a Solvent for Cleaning Spots and Stains	XII	45
Water Spots on Materials, Removing.....	XII	42
Wax Candle, Stain, How to Remove.....	XII	50
Wax, Tailor's, Used for Marking Around Pattern	I	118
Weave, Testing Fabrics for Firmness of.....	XII	35

A COMPLETE COURSE IN DRESSMAKING

	Lesson	Page
What to Wear when you Travel.....	I	12
White Fabrics, Neutralizing Acid Stains with an Alkali.....	XII	45
White Goods, Removing Perspiration Stains from White or Fast Color Fabrics, Removing Fruit Stains from.....	XII	56
Woman's Coat, How to Make.....	XI	1
Woman's Coat, Interlining.....	XI	14
Woman's Dress, How to Make.....	X	1
Woman's Skirt, How to Make.....	IX	1
Wool, all About.....	XII	28
Wool and Silk Mixtures.....	XII	33
Wool, Bleaching with Hydrogen Peroxide.....	XII	46
Wool, Boiling Out Test for.....	XII	33
Wool, Burning Out Test for.....	XII	32
Wool Creasing Test for.....	XII	35
Woolen Fabrics, Weighting and Finishing.....	XII	38
Woolen Yarn Testing.....	XII	37
Wool, How to Recognize Good.....	XII	36
Wool Materials, Finish and Weight of.....	XII	38
Wool, Removing Blood Stains from.....	XII	49
Wool, Removing Coffee Stains from.....	XII	50
Wool, Removing Fruit Stains from.....	XII	51
Wool, Restoring color Destroyed by an Alkali... ..	XII	49
Wool Yarns, Two Kinds in Fabrics.....	XII	37
Worsted Yarn Testing.....	XII	37
Wrap, Woman's Evening.....	XI	27

Y

Yarn Dyed and Piece Dyed Fabrics, Detecting..	XII	39
Yarn Dyed Linen.....	XII	40
Yarn, Quality of in Linen and Cotton Fabrics....	XII	37
Yarn, Quality of in Silk Fabric.....	XII	37
Yarn, Quality of in Wool Fabric.....	XII	37
Yarn, Wool for Embroidery.....	XII	13
Yellow Tones, Avoidance of.....	I	59
Yoke and Collar for Norfolk Coat.....	XI	17
Yoke for Boy's Sailor Suit.....	VII	14
Yoke for a Coat Finished without a Lining.....	XI	34
Yoke for Lady's Wrap.....	XI	27
Yoke, How to Add.....	V	7
Young Girl's Frock, Simplicity the Key-Note for..	I	23
Young Girl's Guimpe Dress.....	VIII	15
Young Woman of Medium Build, Styles for.....	I	28
Youthful Looking Stout Styles, to Acquire.....	I	32
Youth's and Men's Shirt.....	VI	1

